

1979

The stoneware industry at Moingona, Iowa: an archaeological and historical study of Moingona Pottery Works (13BN120) and Flint Stone Pottery (13BN132)

Allen Leo Schroeder
Iowa State University

Follow this and additional works at: <https://lib.dr.iastate.edu/rtd>

 Part of the [Archaeological Anthropology Commons](#), [Ceramic Materials Commons](#), [Other History of Art, Architecture, and Archaeology Commons](#), and the [United States History Commons](#)

Recommended Citation

Schroeder, Allen Leo, "The stoneware industry at Moingona, Iowa: an archaeological and historical study of Moingona Pottery Works (13BN120) and Flint Stone Pottery (13BN132)" (1979). *Retrospective Theses and Dissertations*. 16907.
<https://lib.dr.iastate.edu/rtd/16907>

This Thesis is brought to you for free and open access by the Iowa State University Capstones, Theses and Dissertations at Iowa State University Digital Repository. It has been accepted for inclusion in Retrospective Theses and Dissertations by an authorized administrator of Iowa State University Digital Repository. For more information, please contact digirep@iastate.edu.

The stoneware industry at Moingona, Iowa:
An archaeological and historical study of Moingona
Pottery Works (13BN120) and Flint Stone Pottery (13BN132)

by

Allen Leo Schroeder

A Thesis Submitted to the
Graduate Faculty in Partial Fulfillment of
The Requirements for the Degree of
MASTER OF SCIENCE

Department: Sociology and Anthropology
Major: Sociology (Anthropology)

Signatures have been redacted for privacy

Iowa State University
Ames, Iowa

1979

TABLE OF CONTENTS

	Page
CHAPTER ONE: INTRODUCTION	1
General Background	1
Statement of Purpose	2
Methodology	4
Plan of Presentation	8
CHAPTER TWO: ECOLOGY	10
Location and Geomorphology	10
Coal Resources	15
Clay Resources	17
Fire clay	17
Potters clay	18
CHAPTER THREE: SETTLEMENT OF MOINGONA	23
Early Settlement	23
Railroad Facilities	24
CHAPTER FOUR: THE CERAMIC INDUSTRY IN MOINGONA AS KNOWN FROM ARCHIVAL SOURCES	27
Chronology of the Moingona Potteries	28
Moingona Pottery Works (13BN120)	28
Beginning of pottery works	28
C. R. Collin	32
Fire at pottery works	34
Progress of pottery works	35
S. H. Deering	37
Decline of pottery works	38
Flint Stone Pottery (13BN132)	43
Beginning of pottery	43
Transaction involving lots 1 and 4	44
Close of pottery between 1874-1879	51
Reopening of pottery	53
Network of communication among potteries	54

	Page
Final closing of pottery	57
Summary of Moingona potteries	60
Pottery Manufacturing Processes at Moingona	61
Preparing the clay	62
Shaping the ware	63
Jigger and jolly	63
Throwing	65
Drying the ware	66
Turning the ware	66
Slipping and blueing the ware	69
Firing or burning the ware	70
Salt glazing the ware	72
Selling the ware	72
Prices of ware	78
Wages of potters	81
CHAPTER FIVE: ARCHAEOLOGICAL INVESTIGATIONS	84
Location and Description of the Sites and Surroundings	84
13BN120	84
13BN132	86
Structural Evidence	88
13BN120	88
13BN132	89
General Characteristics of the Ceramic Wares	89
Description of Vessel Types	91
Vessel category: milk pans	92
13BN120	92
13BN132	94
Vessel category: crocks or pots	96
13BN120 (Moingona Pottery Works) cobalt blue and stamped decorations	101
13BN132 (Flint Stone Pottery) cobalt blue and stamped decorations	117
Vessel category: churns	128
132BN120	128
13BN132	129

	Page
Vessel category: jars	129
Lids	132b
Vessel category: jugs	136
Vessel category: flower pots	136
Vessel category: drain tile	141
Miscellaneous vessels from 13BN132	144
Water jar	144
Water or feeder pan	144
Spittoon	146
Well tubing	146
 Kiln Furniture	 146
Category A	147
Category B	148
Category D	149
Category E	149
Category F	150
Category H	152
Category K	152
Miscellaneous artifacts	153
Draw trial and cut and glazed sherds	153
Salt glazed cylinders	155
 Nonkiln Associated Artifacts	 155
 CHAPTER SIX: G. W. CHANDLER COLLECTION	 157
Pottery and Associated Material	157
Pottery	157
Potter's wheel	158
Stencil	158
 Inventions and Patents	 163
Ceramic shoe heels	163
Ceramic railroad tie	163
Ceramic fence post holder	167
 CHAPTER SEVEN: SUMMARY AND CONCLUSIONS	 170
Summary	170
Conclusions Regarding the Stoneware Industry at Moingona	171

	Page
Concluding Perspective on Reasons for Decline of Pottery Industry	172
Epilogue: A Final Glance at the Past and a Look to the Future	176
BIBLIOGRAPHY	178
ACKNOWLEDGMENTS	185
PLATES 1-5	187

LIST OF FIGURES

	Page
Figure 1. Portion of map of Boone County adapted from the Illustrated Historical Atlas of the State of Iowa	11
Figure 2. List of Boone County potteries	21
Figure 3. Map of Moingona modified from Boone County Recorders Office, date unknown, showing approximate location of A) Moingona Pottery Works; B) Flint Stone Pottery	30
Figure 4. Newspaper article on Moingona Pottery Works from <u>Montana Standard</u> : September 2, 1870	33
Figure 5. Advertisement for the Flint Stone Pottery from the <u>Boone County Democrat</u> : April 30, 1873	47
Figure 6. January 25, 1882, price circular of ware of Iowa potteries	56
Figure 7. Jigger and jolly	64
Figure 8. Potter's tools	67
Figure 9. Moingona Pottery Works order form	74
Figure 10. Moingona Pottery Works order form	74
Figure 11. Outside pages of Moingona Pottery Works order form	76
Figure 12. Inside pages of Moingona Pottery Works order form	77
Figure 13. Moingona Pottery Works calling card	79
Figure 14. Flint Stone Pottery order form	80
Figure 15. Map of Saylorville Reservoir (U.S. Army Corps of Engineers 1964) showing general location of 13BN120 and 13BN132 at Moingona	85
Figure 16. Topographic map of the Moingona Pottery Works locality showing location of A,B) kiln mounds; C) well; D) clay pit	

	Page
Figure 17. Milk pan forms: A) type from 13BN120; B) Category A from 13BN132; C) Category B from 13BN132	93
Figure 18. Stamped milk pan rim sherd from 13BN120	95
Figure 19. Decorated crock rims: A,B) from 13BN120; C) from 13BN132	98
Figure 20. Table of frequencies and measurements of large and small diameter crocks from 13BN120 and 13BN132	99
Figure 21. Vessel handle forms: A) found on crocks and churns; B) found on jugs	100
Figure 22. Variations in crock rim forms: A,B) large reserve rims from 13BN132; C,D) small reserve rims from 13BN132; E) large reserve rim from 13BN120; F,G,H) small reserve rims from 13BN120	102
Figure 23. Variations in crock rim forms: A,B) folded rims from 13BN132; C) folded rim form 13BN120; D) straight rim from 13BN120	103
Figure 24. Table of frequencies of cobalt blue decorated sherds from 13BN120 and 13BN132	104
Figure 25. Cobalt blue lettering from Moingona Pottery Works (13BN120): A) Type A; B) Type B	105
Figure 26. Cobalt blue lettering from Moingona Pottery Works (13BN120): A) Type C; B) Type D	106
Figure 27. Cobalt blue lettering from Moingona Pottery Works (13BN120) Type E	107
Figure 28. Cobalt blue leaf designs on sherds from 13BN120	110
Figure 29. Cobalt blue designs on sherds from 13BN120: A) leaf design; B) flower design	111
Figure 30. Cobalt blue flower designs on sherds from 13BN120	112

	Page
Figure 31. Cobalt blue flower designs on sherds from 13BN120	113
Figure 32. Cobalt blue cyclone designs on sherds from 13BN120: A) Type A; B) Type B	114
Figure 33. Cobalt blue cyclone design Type A on sherd from 13BN120	115
Figure 34. Cobalt blue cyclone design Type B on sherd from 13BN120	116
Figure 35. Cobalt blue lettering from 13BN132: A) Type A; B) Type B	118
Figure 36. Lettering on sherds from 13BN132: A) Cobalt blue Type C; B) stamped sherd	119
Figure 37. Cobalt blue designs on sherds from 13BN132: A) Miscellaneous design; B) leaf design	120
Figure 38. Cobalt blue circle design on sherd from 13BN132	121
Figure 39. Cobalt blue butterfly design Type A on sherd from 13BN132	122
Figure 40. Cobalt blue butterfly design Type B on sherds from 13BN132	123
Figure 41. Cobalt blue cyclone design Type A with script three on sherd from 13BN132	124
Figure 42. Cobalt blue cyclone design Type B on sherd from 13BN132	125
Figure 43. Large crock sherd with cobalt stencil from 13BN132	127
Figure 44. Churn rims: A,B) from 13BN132; C,D) from 13BN120	130
Figure 45. Jar rim forms: A,B,C,D) from 13BN120; E,F,G) from 13BN132; H) half section of jar from 13BN120	132a

	Page
Figure 46. Lid forms: A) crock lid from 13BN132; B,C) crock lids from 13BN120; D,E) jar lids from 13BN120	133
Figure 47. Lid forms: A,B) churn lids from 13BN120; C) handled lid for internal channel container from 13BN132	135
Figure 48. Table of frequencies and measurements of jugs from 13BN120 and 13BN132	137
Figure 49. Jug rim forms from 13BN120	138
Figure 50. Jug rim forms from 13BN132	139
Figure 51. Jug rim forms: D,E) from 13BN132; F) from 13BN120	140
Figure 52. Flower pots from 13BN120: A) scalloped rim profile; B) half section of flower pot	142
Figure 53. Cross sections of drain tile from 13BN132	143
Figure 54. Miscellaneous vessel forms from 13BN132: A) half section of water jar; B) cross section of water pan; C) cross section of spittoon	145
Figure 55. Positions of kiln furniture: A) ring on which stack is based; B) disc between the necks of jugs; C) wedges to separate the vertical stacks	151
Figure 56. Draw trial made from a cut rim section of a milk pan from 13BN120	154
Figure 57. Table of measurements of ceramic material of G. W. Chandler from collection of Mrs. Anderson	159
Figure 58. Number stencil of G. W. Chandler from Mrs. Anderson's collection	162
Figure 59. Ceramic shoe heel from collection of Mrs. Anderson: A) bottom view; B) cross section	164

	Page
Figure 60. Patent on railroad ties from Mrs. Anderson's collection	165
Figure 61. Illustration of railroad tie from Mrs. Anderson's collection	166
Figure 62. Patent on fence post holder from Mrs. Anderson's collection	168
Figure 63. Illustration of ceramic fence post holder from Mrs. Anderson's collection	169

LIST OF PLATES

	Page
Plate 1. Moingona Pottery showing location of the main building, the two kilns, and the storage sheds	188
Plate 2. G. W. Chandler's pottery vessels: A) pitcher; B) angel food cake pan; C) butter dish	189
Plate 3. G. W. Chandler's flower pots: A) small flower pot with raised flower designs; B) large flower pot with scalloped lip and saucer; C) large flower pot with scalloped lip and base with pedestal	189
Plate 4. G. W. Chandler's potter's wheel showing wooden frame, throwing wheel, wooden treadle, and kick wheel	190
Plate 5. G. W. Chandler's potter's wheel with front part of wooden frame removed, showing back of wooden base, throwing wheel, iron shaft, wooden treadle, and kick wheel	190

CHAPTER ONE: INTRODUCTION

General Background

Saylorville Dam, located northwest of Des Moines, along the Des Moines River, was completed in 1977. Construction of the dam and the subsequent filling of the reservoir destroyed and continue to endanger many archaeological sites containing important data pertaining to the prehistory and early history of the Des Moines River Valley. This study undertakes an archaeological and historical investigation of two nineteenth century industrial sites which may be threatened by the operation of Saylorville Reservoir and peripheral developments (see Figure 1 and Figure 15). Beyond the concerns of salvage archaeology and the preservation of environmental data, the investigation of these two early stoneware manufacturing operations will contribute not only to a better understanding of the development and eventual decline of the ceramic industry in Iowa but also to a fuller perspective in which to view the socio-economic strategies involved in the Euro-American settlement and exploitation of ecological resources in the region.

The two stoneware manufacturing enterprises involved in this study are the Moingona Pottery Works and the Flint Stone Pottery - designated respectively as archaeological sites

13BN120 and 13BN132 in the Smithsonian Trinomial System¹. Located in the unincorporated village of Moingona, Iowa, these two potteries were in operation between 1869-1883. During that time period they were among the largest ceramic industries in central Iowa, providing inexpensive containers for the preparation and storage of food for the early pioneer settlements in the midwest. Pottery manufacturing was the second largest industry, after coal mining, in Moingona.

Statement of Purpose

This study attempts an archaeological/historical reconstruction of the socio-cultural activities associated with the Moingona potteries. Few publications exist concerning the nineteenth century ceramic industry in Iowa, especially in regard to individual potters and potteries. To acquire more information one must search for available documents and other archival sources. Ivor Noel Hume (1969:18) states that "Historical research is just as much a part of historical archaeology as digging holes in the ground. . . ." Noel Hume (1969:27) also cautions that historical evidence can be

¹In the Smithsonian Trinomial System the first unit specifies the state in which the site is located, 13 is the number of Iowa in an alphabetically arranged list of states; the second unit indicates the county, BN is the designation of Boone County; the third unit refers to the number of the site within the county, 120 and 132 are the numbers of the sites within Boone County.

misinterpreted and that

Whenever possible, the documents should be allowed to speak for themselves, for, once written down, the historian's interpretation of the evidence can become indistinguishable from the facts themselves.

This report, therefore, attempts to include the exact archival data related to the ceramic industry in Moingona and thus, hopefully, lets the documents "speak for themselves."

Along with the archival data information was also gathered dealing with archaeological remains of the Moingona potteries. Surface collections were made on various occasions between June 1969 and February 1974. Initially it was hoped that a representative sample of archaeological material would provide information about the age of the pottery and the identity of the potters. The enormous amount of material present on the surface precluded any initial attempt at total recovery. Instead a sample of the various types of pottery was collected and it was upon this sample that the archaeological analysis was based. Interpretation of the archaeological material is possibly even more critical than the interpretation of the archival data because as Noel Hume (1969:28) states:

The archaeologist must always remember that when he writes his final excavation report he is adding to the corpus of documentary evidence and that if the report misleads or confuses he would have been better advised to have neither written nor dug.

This archaeological and historical investigation can provide a better understanding of the nineteenth century ceramic industry in Moingona and its relationship to other potteries and related industries in Iowa and surrounding states. The investigation can hopefully provide a better understanding of the inter-connection of historical events which were taking place throughout the Midwest during the latter part of the nineteenth century. It can also contribute to the ecological perspective in exploring the extent and ways in which the natural resources of the area were utilized. Finally it can shed some light on the strategies which Euro-American settlers on the frontier evolved as they adapted to the changing technological and economic patterns of the nation as a whole.

Methodology

Historical data must be critically evaluated and not unquestionably assumed to be correct. Likewise the archaeological data must be carefully interpreted because as Noel Hume (1969:28) states:

Archaeological conclusions can rarely be as firm and unassailable as the written word, for while a document can categorically state this is the way it was, the archaeologist can generally go no further than saying that this seems to be the way it was. . . . The evidence is reviewed and possible conclusions drawn, but they remain deductions and not facts, and that is how they must be presented.

The historical data were acquired from a variety of sources such as census records, land deeds, newspapers, atlases, early history books, shipping records, order forms, personal letters, abstracts of land, and minutes of the Moingona town council meetings. Much of the archival information came from the collected material of G. W. Chandler, a Moingona potter. This latter material is in the possession of Mrs. Eloise Anderson, a granddaughter of G. W. Chandler. Mrs. Anderson, who lives at 1234 East 13th Street in Des Moines, Iowa, graciously permitted me to examine G. W. Chandler's material which includes letters, business records, patents, a variety of pottery, and a potter's wheel. Any of the above articles referred to in this report will be referenced as follows: (Anderson 1974), in order to simplify the recording of their location. The minutes of the Moingona town council meetings are in the possession of Mrs. Olive Kennedy of Moingona.

There are problems involved in the use of much of the archival data. Hand written documents such as census records, land deeds, and letters, are often difficult to read and decipher accurately. Boone newspapers provided a major source of information. They included the following: Boone County Advocate, Boonesboro Democrat, Boone County Democrat, Boone County Index, Boone County Republican, Boone News Republican, and Montana Standard. The above newspapers were located at

either the Erickson Public Library in Boone, Iowa, or at The State Historical Society of Iowa in Iowa City, Iowa. A major problem with the newspaper accounts was the missing issues of the Boone County Advocate between December 22, 1870 and August 15, 1872 and the Boone County Democrat between August 24, 1870 and February 26, 1873. This three year time period was important because it covered the completion and early operation of the Flint Stone Pottery. Another problem presented by newspapers was the inaccurate reporting and conflicting information found in many of the newspaper articles. Also newspaper accounts very often did not include the first name or initials of individuals mentioned, and the last names were often misspelled. The following names associated with the Moingona potteries were spelled several different ways: Titman and Tietman [sic]; Atchison and Atchinson [sic], and Atkinson [sic]; Hutchinson and Hutchison [sic]; Henderson and Hendersen [sic]. In addition to these names being misspelled there were often no first names or initials given, making it difficult to determine if the newspaper accounts were referring to the same or different individuals. The misspellings also occurred in other archival data. There were also issues of the newspaper missing which left gaps in the account of the ceramic industry in Moingona.

There are somewhat different problems with the early histories of the various counties in Iowa. The information

for a county's history was often compiled in less than a month's time thus obviating the necessary cross-checking of many details. Also recognition of a county's prominent residents was based as much upon monetary considerations as upon noteworthy achievements of the individuals. It is important that one is aware of the problems involved using archival data so that information can be cross-checked wherever possible to verify its accuracy.

The archaeological data, the material remains of the past, are as Ivor Noel Hume (1969:10) has stated: "waiting to fill in the missing pages of history - provided that we can get to it in time." Archaeological data obtained from the two stoneware pottery sites consisted of the surface collections of portable artifacts and the visual observation of the ruins of probable structural remains. Thick vegetational ground cover -- including trees, thick grass, nettles and poison ivy -- and steep hill slopes made the collection of surface artifacts and the definition of buried structures difficult. Nevertheless an attempt was made to obtain a general representative sample of all vessel ware and glaze categories in addition to all varieties of kiln furniture. At the same time all observed sherds with manufacturers marks were collected so that specific linkages could be verified between the archaeological residues and the information in the archival sources.

Because these two potteries are historic sites there is documentary evidence to generally identify most of the artifacts, which is not the case with the prehistoric sites. Documentary evidence was used whenever possible in the identification of artifacts from the Moingona potteries. This evidence included such sources as shipping books, order forms, and contemporary publications dealing with nineteenth century American pottery.

The archaeological material from the two potteries verified much of the archival data in terms of identifying the sites, the general types of ware produced, and the technology involved in pottery manufacturing. On the other hand the archaeological collections provided examples of manufacturers marks, design elements, vessel form variations, and specific glaze combinations not mentioned in the archival sources. Furthermore the archaeological collections included wares such as water or feeder pans and well tubing which were not recorded in the available documents.

Plan of Presentation

The following discussion is divided into seven main sections. Chapter Two deals with the ecology, geology, and geomorphology of the historical region in which the potteries operated. This chapter focuses upon the local natural resources of coal and clay which were vitally important to

the ceramic industry in Moingona. Chapter Three deals with the settlement of Moingona, its beginning and first businesses and the importance of the railroad in its development. Chapter Four, (which is divided into two parts) discusses the ceramic industry in Moingona. The first part brings together scattered archival data through which the chronology of each pottery can be reconstructed. The second part discusses the process of pottery manufacture from the first digging of the raw clay, through construction of the ware and sale of the finished product. Chapter Five provides a detailed discussion of the archaeological investigation undertaken at the two sites. A description and classification of the surface inventory is given for each site in order to establish consistent terminology that will help identify the ceramic debris left behind at these sites. Chapter Six presents a brief account of the collected material of G.W. Chandler, a Moingona potter. Descriptions and measurements of Chandler's ceramic material is provided as well as examples of patents he had on various ceramic inventions. The final chapter of the thesis is a synthesis of the archaeological and archival data. Factors accounting for the inception, flowering, and eventual collapse of the Moingona ceramic industry are suggested.

These two Moingona potteries represent only a small part of the total ceramic industry in Boone County. It is hoped that by continued archaeological investigation other sites will be discovered that will aid in preserving an important part of the early industrial history of Iowa.

CHAPTER TWO: ECOLOGY

Location and Geomorphology

The town of Moingona lies in Marcy Township of Boone County in the NE $\frac{1}{4}$ of section 12, township 83N, and range 27W (Figure 1). The first three town plats in Marcy Township were Quincy, platted November 2, 1854; Moingona platted July 6, 1866; and Coal Valley platted September 1867 (Goldthwait 1914: 282-284).

Moingona is located on the west bank of the Des Moines River, the principal river in Boone County. The Des Moines River enters the county a mile west of the center of the northern boundary, pursues a southeasterly course, and leaves the county four miles east of the center of its southern boundary (Goldthwait 1914:264). The Des Moines River is younger than the glacial deposits which form the Des Moines River Valley (Beyer 1896:183). In the vicinity of Moingona there are several smaller streams which flow toward the Des Moines River: Mill Creek ran west to east through the northern part of Moingona. Pole Cat Creek started north of Boonsboro and ran south to a point about one mile northeast of Moingona where it met Honey Creek. Honey Creek began in the southeast corner of the city of Boone and ran southwest, meeting Pole Cat Creek, then continuing on into the Des Moines River. The Des Moines River along with the other

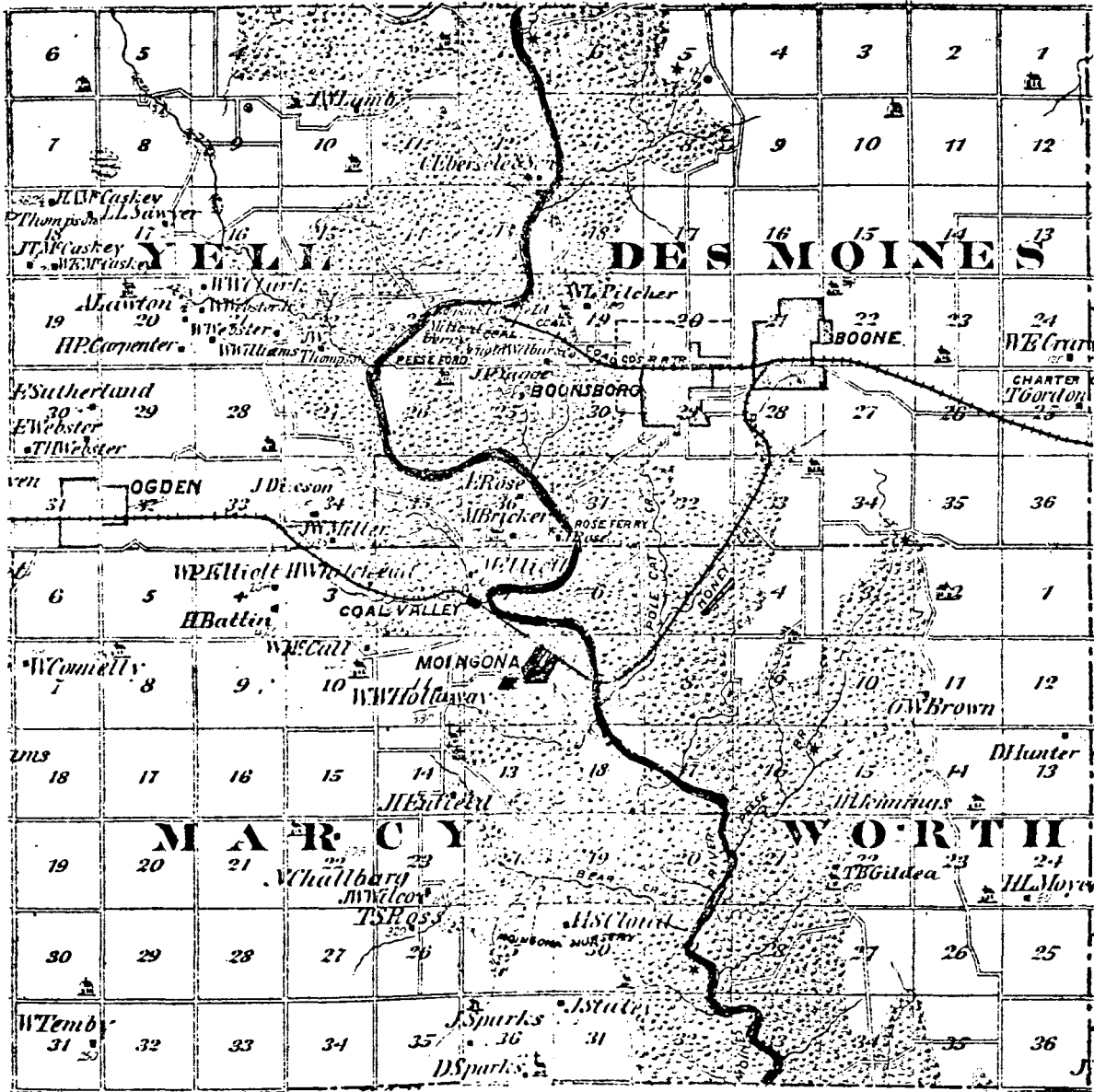

Figure 1. Portion of map of Boone County adapted from the Illustrated Historical Atlas of the State of Iowa (Andreas 1875:100)

three streams were important in supplying a source of power to run the many flour and saw mills erected along their courses. These mills included the following: Lord's grist mill, Doran's saw mill, Messmore & Lord flour mill, Sparks and Adams saw mill, and A. Hartman and Brother flouring mill (Brown 1971:4; Boone County Advocate: February 17, 1870; Boone County Democrat: December 24, 1873; Boone County Democrat: April 28, 1880; Boone County Democrat: December 9, 1874).

Some of the best timber in the state was also found along the banks of these rivers and was an important natural resource for both the prehistoric and historic settlements. Timber provided fire wood for cooking and heat, a habitat for a variety of wild game for food, and a variety of lumber for building purposes. Among the most abundant of the original trees found was the black walnut, being highly prized, its stands became rapidly depleted. Other timber included red, white and black oak, crab apple, elm, maple, ash, cottonwood and wild cherry. The line of timber which followed the course of the Des Moines River averaged four miles in width (Goldthwait 1914:265). Timber was used extensively for the construction of railroad ties and bridge piers for the Chicago and NorthWestern Railroad which was making its way across Iowa in the late 1860's (Brown 1971:4). Timber was also important for building construction. The Sparks and Adams saw

mill in Moingona, employing ten men in 1873, and producing 3000 feet of lumber daily, had trouble keeping up with the demand (Boone County Democrat, December 24, 1873).

The topography of Boone County is characterized by a moraine composed of a chain of interlocking hills one to three miles in width and extending three-fourths of the way across the northern part of the county. The central and southern portions of the county are characterized by an undulating surface slightly inclined toward the south (Beyer 1896:180).

Two main types of soils are associated with the topography of Boone County, alluvium, and drift deposits. Alluvial soils are the "bottom" lands along the rivers and streams and are comprised of the washings of other soils mixed with decayed vegetable matter. Drift soil is derived primarily from the disintegration of rocks through glacial action. Drift soil, occupying the greater portion of the state, forms the soil for all of the higher plains and woodlands, except for the loess bluffs located along the western border of the state (Goldthwait 1914:267).

The two most important geological formations that played a major role in the development of Moingona were coal and clay.

Coal Resources

Coal, obtained from outcroppings along the river banks, was used by the earliest settlers of Boone County, but it was not until 1865 that any coal mines were opened. In 1865 the Chicago & Northwestern Railroad reached the Des Moines River and opened a market for all the coal that could be mined. The railroad company began firing their engines with coal from Moingona and coal also supplied the towns that lay to the east along the railroad line. In 1868 there were some 70 individuals engaged in the mining of coal in Boone County (Boone County Democrat: December 30, 1868). By 1869 there were eight different firms operating some ten coal mines in Boone County. Three of these firms were operating in the immediate vicinity of Moingona: the Moingona Coal Company, which was the largest of the three, the Northwestern Coal Company, and the Des Moines Valley Coal Company. The coal from the various mines in Boone County was used as follows, according to an article in the Montana Standard (January 15, 1870):

	Bushels
For Railway use at Montana [now Boone]	312,639
For Railway use at Moingona	819,031
Shipped at Montana [now Boone]	93,751
Shipped at Moingona	527,861
Home use etc. [sic]	500,000
Total	2,253,422

The above cited newspaper account shows Moingona to be an important center for the shipping of coal. The mining of coal became Moingona's leading industry. The coal was mined from the Coal Measures which Charles A. White, the state geologist in 1870, describes as follows:

There are two distinct beds of coal known and mined here, the principal one being the lowest and about four feet thick. The upper one is from two and a half to three feet thick. The quality of the coal is equally as good as that of the other, but requiring proportionally, more labor, it is not so extensively mined (White 1870:259).

Two specific stratigraphic sections at Moingona were detailed by Beyer (1896:191-192) in the 1896 geological survey of Boone County:

Coal measure strata exposed about one-half mile northwest of the town of Moingona, along the Chicago & Northwestern Railway, are as follows.

	Feet	Inches
11. Drift, in the main, a light blue, gritty clay, with numerous small lime concretions, extends about fifteen [sic] feet below the road bed	50	
10. Sandstone, shaly, alternating with sandy shales; predominantly ash-gray in color and calcareous	12	
9. Shale, blue	4	
8. Sandstone, shaly and sandstone, compact	4	
7. Shale, black	2	
6. Coal		3
5. Fire clay and shale	7	
4. Shale, containing many ferruginous concretions and stems of <i>Lepidodra</i>	4	
3. Shale, blue-black, containing <i>Lingula umbonata</i> Cox, in places	2	
2. Coal	2	
1. Fire clay, exposed	2	

About one mile north of this point the following sequence of strata may be observed.

(Tp. 83 N., R. XXVII W., Sec. 1, S. $\frac{1}{2}$, SE. $\frac{1}{4}$)

	Feet
7. Drift and displaced material	40
6. Sandstone, compact ledge	1
5. Sandstone, ash-colored, clayey and somewhat fissile: state of induration very variable, pockets of fine sand occur in the upper portion while the lower part takes on a concretionary structure	45
4. Shale, blue-black	2
3. Coal	2
2. Fire clay	3
1. Sandstone, exposed	3

A study of these two stratigraphic sequences shows the occurrence of the economically significant fire clay as well as coal at Moingona.

Clay Resources

Fire clay

As shown in the previously discussed stratigraphic sections, local clay resources were available for the manufacture of pottery and brick. Fire clays usually form the underclays for the principal coal seams. They show no stratification or other structural features and are non-fissile. Fire clays are so named because they are low in fluxes, making them resistant to fire. They usually burn a light color, due to the partial loss of iron, the main coloring agent in clays. Iowa fire clays vary in thickness from a few inches to four or five feet, and are used in the

manufacture of the higher grades of ware, such as face and fancy brick, pottery, terra cotta and sanitary ware (Beyer and Williams 1904b:411-412). Fire brick was probably the most frequent product made of fire clay because of the refractory characteristics of the clay. One of the main uses of fire brick was in the construction of kilns. These bricks would not lose their shape during firing as readily as common brick. A more commonly used clay for the manufacture of stoneware was potters clay.

Potters clay

The clay used by the various ceramic industries could be acquired from three main sources: alluvium soil, drift soil, and Coal Measure shales. Clay shales are found in the Coal Measures and are often exposed along the Des Moines River and its tributaries. Shale clays are commonly not very plastic clays, but become very plastic when finely ground or subjected to weathering. The Coal Measures are overlain by a thick deposit of glacial drift composed largely of calcareous clay. The upper portion of this drift material is generally covered to a depth of two to five feet by a brown to grayish alluvial like soil. From these soils is acquired the clay used in the manufacture of pottery, brick, and tile (Beyer and Williams 1904c:44-51; Goldthwait 1914:267; Beyer 1896:222). Alluvium clay was used by several of the brickyards in Moingona and

drift clay and the shale clay were used at brickyards west and southwest of Boone (Beyer 1896:222).

Coal Measure shales were used by the Boone Clay Works located about two and a half miles southwest of Boone. The following is a section of an exposed bank from which the Boone Clay Works was getting its clay in 1889:

	Feet
9. Drift	15
8. Potters Clay	1½
7. Clay shale, steel-colored	2
6. Clay shale, gritty, ash-colored, iron-stained in the upper part	4
5. Clay shale, colored red, blue and gray	12
4. Shale, deep red, ochreous band	2/3
3. Clay shale, similar to 2	2
2. Fire clay	1½
1. Shale, impure (exposed)	3

(Beyer 1896:223-224).

Drain tile was the principal product made from the shale clay while the fire clay was used to make fire brick (Beyer 1896:224).

Alluvial clay was used by the Slater brickyard in Moingona. The material used was known as "white oak" clay, a light colored soil that was taken from a hilltop south of the brickyard. The clay was used to a depth of about two feet and then was followed by a yellow, somewhat gravelly clay, which contained numerous particles and concretions of lime. Some brick was also made from a red shale outcrop, three to six feet in depth, near the Moingona Coal Company shaft No. 6 (Beyer 1896:225-226).

Lime-bearing drift clay mixed with loamy material was found on the slopes of hills, generally a few feet below the alluvial surface (Beyer 1896:222). This drift clay is part of a larger drift deposit consisting of irregularly stratified beds of sand, gravel, and clay, having an average thickness of from forty to sixty feet (Goldthwait 1914:267). Drift clay was used by M. W. Griffie Pottery in Boone, and was obtained from the east bank of Diamond Hollow, about a third of a mile east of the Des Moines River. The clay bed was two feet thick, with the upper two to three inches being a dark gray color; under this was a buff, siliceous clay which was sandier in the lower portion. The two clays were mixed through the process of mining into the side of the hill. Over the clay was a limestone ledge and under the clay was sandstone (Beyer 1896: 225-226).

The manufacture of ceramic products in general was an important industrial and economic factor in the history of Boone County. Pottery and other stoneware products were manufactured from the 1850's to at least the 1880's. By the end of the nineteenth century, however, no pottery firms were in operation in Boone County so far as is known. Figure 2 lists the Boone County potteries as presently known from archaeological evidence and written documentary sources (Boonsboro Democrat: January 2, 1862; Boone County Democrat:

Approximate Date	Archaeological Site Number Assigned by Iowa State University	Name of Firm or Owner	General Location
1856		Keigley & Terry	Boonsboro
1862		S. A. Kelsey	Boonsboro
1870		Kegley, Hyten & Co.	Boone - 3rd & Webster
1870	13BN138	M. W. Griffee & Co.	Boone - E 5th & Webster
1869	13BN120	Moingona Pottery Works	Moingona
1871	13BN132	Flint Stone Pottery	Moingona
1872	13BN111 "Noah Creek Kiln"	Coal Valley Pottery Comfort & Elliott	Coal Valley
1872		Burley, Hess & Starr	Boonsboro
1875		W. D. Wright John F. Hyten Wm. F. Stringer M. A. Griffee	Boonsboro Boonsboro Boonsboro Boonsboro
1879		Hess & Terry	Boonsboro
1879		D. F. Hess	Boonsboro
1880	13BN131 "Franklin Kiln"	T. R. Franklin Ezariah Stringer	Stringer Creek in West Boonsboro

Figure 2. List of Boone County potteries

October 7, 1868, October 3, 1872, and July 23, 1879; Boone City Directory 1897; Anderson [1974 (Oct. 4, 1875)]; Gradwohl 1973; Andreas 1875:577). The "Noah Creek Kiln" (13BN111), located at Coal Valley, is extensively described in a Master's thesis written by Barbara Schulte (1974).. The Moingona Pottery Works and Flint Stone Pottery, located at Moingona, are dealt with further in subsequent chapters of this thesis.

The ceramics industry in Boone County, of course, included the manufacture of bricks and tiles. The production of these items extended into the twentieth century as shown in the 1903 directory of Iowa clay workers (Beyer and Williams 1904a:624). As of that year, the following ceramic firms were producing bricks and tiles: Boone Brick, Tile and Paving Company, A. E. Goldthwait, McHose Brothers, Fred Carlson, John Slater, and Scandia Brick and Tile Company. The economic feasibility and the consumer demand for locally produced construction brick and drainage tile thus outlasted these factors as they pertained to pottery and other stoneware products.

CHAPTER THREE: SETTLEMENT OF MOINGONA

Early Settlement

Moingona is located at the confluence of the Des Moines River and Mill Creek (see Figure 1 and Figure 3). The farm land upon which the town was built initially belonged to Montgomery McCall, one of the earliest settlers in Boone County (Goldthwait 1914:306). Originally platted in July of 1866, the town is said to have been named "Moingona" by a niece of John I. Blair, president of the Moingona Coal Company and manager of the Chicago and North~~west~~ern Railroad (Boone County Democrat: December 30, 1868). Although there is considerable controversy as to the ultimate derivation of the term "Moingona" (cf. Boone County Democrat: October 30, 1878; Goldthwait 1914:264; Brown 1971:7), that name was used in various eighteenth century journals and maps in relation to the Des Moines River. Thus the settlement was not only located but was designated in reference to the river.

The first house, constructed in Moingona in July, 1866, by Stephen Dows & Company, also served as a store. After that the town grew and diversified quickly. Two years later, according to a newspaper article in the Boone County Democrat (December 30, 1868), Moingona had a population of about 900 people. There were 300 town lots, each measuring 60X142 feet and costing between \$200 and \$300. The main streets were 80

feet wide. A list of business firms, merchants, and professional people established in the town as of December 30, 1868, indicates that:

There are 4 general stores, 1 clothing store, 1 merchant tailor, 1 harness shop, 3 boot and shoe shops, 2 millinery shops, 2 hardware stores, 1 furniture dealer, 1 hotel, 2 blacksmith shops, 1 wagon maker shop, 1 carpenter and joiner's shop, 2 fruit and confectionery stores, 2 meat markets, 1 bakery, 1 grist mill, 1 saw mill, 1 lumber yard, 1 attorney, 1 physician, 1 real estate and insurance agency, etc. (Boone County Democrat: 30, 1868).

In addition there was the brickyard established in Moingona by John Slater on January 1, 1866 (Clarke 1902:575) and the three previously discussed coal mining companies which were operating in this locality.

Railroad Facilities

Railroads, particularly the Chicago & Northwestern, played an important role in the settlement of Boone County. Many of the towns located along the Chicago & Northwestern line were originally established as railroad stations, for example Boone, Moingona, Ogden, and Beaver. The railroad provided a means of transporting freight to and from distant markets, and this was one of the main reasons coal began to be mined in Boone County. The route of the Chicago & Northwestern Railroad began when John Insley Blair combined two short line Iowa railroads, the Chicago, Iowa and Nebraska

Railroad and the Cedar Rapids & Missouri River Railroad, with the Chicago & NorthWestern. With capital from eastern financiers, Blair began to extend the railroad line from the Mississippi to the Missouri across Iowa reaching Boone in 1865 and Moingona in 1866 (Boone News Republican: September 13, 1965:4-8).

After the railroad reached Boone the likely route of the line would have been to continue straight west through Boonsboro and across the Des Moines River. However, the people of Boonsboro could not raise the \$10,000 Blair demanded as a condition for the railroad to go through Boonsboro. Secondly, it was decided that the cost of building a railroad bridge across the Des Moines River west of Boonsboro would be prohibitive. A newspaper account details this decision:

West of Boonsboro the bottom on one side or the other is wide and the grading, after a bridge is built, would cost about as much as the bridge itself. The Cedar Rapids and Missouri River Railroad Company decided that point when they built their road in 1866. They preferred to lengthen their line and run down Honey Creek rather than take the "short cut" and incur the heavy expense of building a bridge west of Boonsboro. An engineer of that company once told us that they saved at least \$100,000 by changing the line to Moingona (Boone County Republican, March 21, 1877).

In this way Moingona was the beneficiary of the economic support of the railroad. When the railroad line turned south at Boone, rather than continuing west through Boonsboro, the

decline of Boonsboro was inevitable as was the rise of Boone and Moingona as the important cities in Boone County.

After establishing a railroad station in Moingona the railroad later added a two stall engine house, a pumping station, two railroad water tanks and express office (Brown 1971:4). In 1868 the Chicago & NorthWestern had four stations in Boone County: Montana (Boone), Moingona, Ogden and Beaver. The Moingona station soon became the leading station for the amount of coal shipped (Montana Standard: January 15, 1870). It was within the socio-economic milieu of coal mining and railroad transportation that the potteries functioned as part of the total ecological setting.

Just as Moingona prospered from the establishment of the railroad line it also waned in part due to the discontinuance of the railroad line through town. A "high bridge" was eventually built west of Boone across the Des Moines River. The new route considerably shortened the line and made it unnecessary to go through Moingona. The last train went through Moingona in 1927 and the tracks were taken up in 1934. By that time Moingona was not much more than a ghost town compared to its more prosperous days in the 1870's (Brown 1971: 4,7).

CHAPTER FOUR: THE CERAMIC INDUSTRY IN MOINGONA AS
KNOWN FROM ARCHIVAL SOURCES

The primary source of information about the ceramic industry in Moingona came from archival sources. The sources of archival data included: census records from 1850 through 1895, Boone County newspapers from 1856 through 1887; Boone County land deed records for the years 1869, 1870, and 1892, Moingona town lot deed records for the years 1871, 1874, 1879, and 1895, minutes of the Moingona town council meetings, abstracts of land in Moingona, personal letters and business correspondence of G. W. Chandler from 1858 to 1904, shipping books and order forms used during the period when G. W. Chandler and S. H. Deering operated the Moingona Pottery Works from 1875 to 1877, and a photograph of the Moingona Pottery Works from around 1874-1876. Archival material provided information such as: when the potteries were erected and when they ceased operation, who worked at the potteries and when, what was manufactured at the potteries, and the process of manufacturing used by the potteries.

Throughout the discussion of the Moingona potteries there were many people associated with the potteries who were also involved in various other businesses. In order to show the extent of this economic web, information about individual participation in businesses not directly related to the

pottery industry is included in the following discussion.

Chronology of the Moingona Potteries

Moingona Pottery Works (13BN120)

Beginning of pottery works The pottery industry in Moingona began in the spring of 1869 when Henry Parkhurst and Oliver C. Atchison began erecting a pottery. The first reference to the pottery is found in May of 1869 in the Montana Standard newspaper.

We learn that a large Pottery is about to be erected in this place; the site has been selected, and work will be commenced upon it in a few days. We are glad to see this movement towards manufacturing in our town (Montana Standard: May 15, 1869).

Henry Parkhurst began erecting the pottery after he was forced to resign as agent for the Moingona Coal Company because of poor health. William Blair, of the firm Blair & Couch, merchants in dry goods and groceries, succeeded Parkhurst as agent of the Moingona Coal Company. The pottery was under the title of H. Parkhurst & Company with Atchison as the manager (Montana Standard: June 19, 1869; Boone County Democrat: July 21, 1869; Montana Standard: February 12, 1870).

The land on which the pottery was erected was bought by Henry Parkhurst from John I. Blair, manager of the Chicago & North~~W~~estern Railroad and President of the Moingona Coal Company. William and John I. Blair were cousins (Montana

Standard: December 12, 1868). The land is described in the warranty deed as commencing at a point nine chains west of the NE corner of section twelve, T83 R27, west 5 chains, south 4 chains, east 5 chains thence north 4 chains to place of beginning (Boone County Town Lot Deed Record: February 28, 1870, Book 5:187 and Transfer Book Town Lots: August 11, 1869, Book A;196). The approximate location of this land is shown on a map of Moingona in Figure 3.

The newly erected Moingona pottery is described as follows in an article in the Montana Standard newspaper on November 27, 1869:

In June last the buildings of the Moingona Pottery were commenced at Moingona by Messrs. Parkhurst and Atchison. These gentlemen have put up a large building of 40 by 45 feet and three stories high. There are also sheds for fuel, the storage of ware, and grinding clay, covering an area of 64 by 24 feet. The pottery has been active and successful operation about three months. Twelve hands are in employ, and they are now burning a kiln of about 2,800 gallons every ten days. The capacity of the institution is much greater, and the second kiln which is to be immediately built will allow of making 5,000 gallons per week, the quantity it is proposed to regularly turn out. The clay used is obtained from the bluff on the brow of which the buildings stand, the underlay sandstone, and the overlay a bed of soapstone above which is sandstone. The mining of it is as yet very little trouble as the bed is practically and [sic] outcrop. This pottery is supplied with many conveniences that can be foreseen and provided for when building the whole structure at once. Everything about the premises is well managed and neatly kept. The product of the pottery is very favorably known in the general market although so recently brought in, and all circumstances promise very successful results in reward for the expense and skill invested.



Figure 3. Map of Moingona modified from Boone County Recorders Office, date unknown, showing approximate location of A) Moingona Pottery Works; B) Flint Stone Pottery

Handwritten scribbles and marks, possibly initials or a signature, located in the bottom right corner of the page.

A photograph with the caption "Moingona Pottery" apparently refers to the Moingona Pottery Works because the other pottery was known as the Flint Stone Pottery. This photograph shows the location of the main pottery building, the two kilns, and the storage sheds (Plate 1). Further evidence as to the identity of the pottery in the photograph is based upon newspaper descriptions of the two Moingona potteries. The pottery shown in the photograph appears to be the wooden Moingona Pottery Works (Montana Standard: November 27, 1869) rather than the brick Flint Stone Pottery (Boone County Advocate: December 8, 1870). The above article also mentions the pottery employed twelve people and from the unpublished original 1870 Official Iowa Census, Volume 104, the following names are connected with the pottery business in Moingona.

Name	Age	Occupation
Oliver C. Atchison	27	works in pottery
Abraham Brown	28	works in pottery
George W. Chandler	38	works in pottery
Charles R. Collin	38	Pres. of Pottery Works
Sylvester Hobart Deering	17	works in pottery
Martin S. Hartman	16	works in pottery
Ebenesor Hartwell	26	potter
John Parkhurst	17	works in pottery
Olsen Vail	62	works in pottery

I believe the above named people are associated with the Moingona Pottery Works because the Flint Stone Pottery was not started until December of 1870 and completed in January of 1871 (Boone County Advocate: December 22, 1870) which

would be after the 1870 Census.

On January 1, 1870, the pottery was incorporated under the name of the "Moingona Pottery Works" and the notice of incorporation appeared in the Montana Standard on February 12, 1870. Their first newspaper advertisement also appeared in the Montana Standard the same day (Figure 4).

On February 28, 1870, Henry Parkhurst and his wife Mary E. Parkhurst were paid three hundred dollars by the Moingona Pottery Works for the land previously described on which the pottery was located (Town Lot Deed Record, Boone County, February 28, 1870, Book 5:187). Henry Parkhurst's health did not improve. He died March 26, 1870, and was buried in Marion, Iowa. In May Mrs. Parkhurst and family moved to Marion (Boone County Democrat: March 20, 1870 and May 4, 1870).

C. R. Collin Charles R. Collin succeeded Henry Parkhurst as President of the Moingona Pottery Works. Collin was originally with Blair, Couch & Company, a dry goods and grocery business (William Blair, C. N. Couch and C. R. Collin). On September 1, 1868, Collin left the firm and bought the store near the crossing at Coal Valley (Boone County Democrat: September 23, 1868). The record is not clear as to how long Collin ran the crossing store or whether he was running the store and the pottery at the same time. Tracing the career of C. R. Collin we find that in December of 1874, he and his

New Advertisements.

H. PARKHURST. M. L. ELLIOTT.
Pres. & Treas. Supt. & Sec'y.

MOINGONA POTTERY WORKS,
Moingona, Boone County, Iowa.

MANUFACTURERS OF

Stone-Ware.

Our ware is made from clay equal in quality to any clay west of New Jersey. We have the most extensive establishments west of the Mississippi river. We employ none but first-class workmen and offer for sale none but first-class ware. We guarantee that they will hold. Kerosene, Brine, Hot Lard and Oil. A large assortment of ware kept on hand constantly and orders promptly filled. Address all orders to
6-47 M. L. Elliott, Superintendent.

NOTICE OF INCORPORATION.

Notice is hereby given that an incorporated Company under the name of the "Moingona Pottery Works" was on the first day of January A. D., 1870, duly organized under the Laws of the State of Iowa.

The principal place of doing business will be at Moingona, Boone County, Iowa.

The business of the Company is to Manufacture Stone and Earthen Ware and any and all articles that can be manufactured from Clay of all kinds.

The Capital Stock authorized is Fifty Thousand Dollars.

The Capital Stock subscribed for is Ten Thousand Dollars to be paid up on or before March 1st 1870.

The time of commencing business was January 1st, 1870, and to continue for twenty years.

The business of the Company will be managed by a President, a General Superintendent, a Treasurer and Secretary, who shall be elected annually on the second Tuesday of January of each year.

The indebtedness of the Company shall never exceed two-thirds of the capital stock paid in.

The private property of the stock holders is exempt from the Corporate debts.

Until the first regular meeting of the stock holders, H. Parkhurst is President and Treasurer and M. L. Elliot is General Superintendent and Secretary.

H. PARKHURST
Moingona Feb. 7th. 1870 President.
6-54w4.

Figure 4. Newspaper article on Moingona Pottery Works from Montana Standard: September 2, 1870

family moved to Elgin, Illinois. In 1876, Collin was an agent for the Victor washing and wringing machines, and in 1885 he was connected with the U.S. and Canada Dealers Protective Association (Boone County Democrat: December 23, 1874; May 17, 1876; September 2, 1885). On September 7, 1881 there was a tax sale in Coal Valley and C. R. Collin's name appears, this tax sale may have included the crossing store that Collin bought in 1868 (Boone County Democrat: September 7, 1881).

Fire at pottery works In July, 1870, the Moingona Pottery Works began erecting a new kiln. The Boone County Advocate has the following account of this event.

We notice another kiln in process of erection at the Moingona pottery works, which indicates an increase in the demand for their ware. We found the superintendent of the works (C. R. Collins) away, but must necessarily come to the conclusion that these works surpass anything of the kind in central Iowa (Boone County Advocate: July 14, 1870).

Before the new kiln was even fired misfortune befell the pottery. On the evening of July 20, 1870, there was a fire at the Moingona Pottery Works. The engineer of the Chicago & Northwestern Railroad, Arthur Finnegan, discovered a fire in the roof of the warehouse. He immediately began blowing the train whistle and managed to arouse the townspeople to come to his aid. Finnegan was able to save the newly erected kiln, which was twelve feet from the warehouse, by climbing to the top and watering it down with water provided by a bucket

brigade to the Des Moines River. The warehouse was lost but the fire was kept from spreading to other pottery buildings and 2000 cords of wood which were in close proximity to the warehouse. The loss was estimated at about a thousand dollars which was covered by insurance (Boone County Democrat: July 27, 1870; Montana Standard: July 23, 1870).

Progress of pottery works By August of 1870 the pottery was back in complete working order and the Boone County Democrat provides a general discussion about the Moingona Pottery Works.

We spent a portion of last Saturday in the sprightly village of Moingona, famous for its coal enterprise and energy of its inhabitants. The Moingona Pottery Works are now in complete order, and turning out a large amount of stoneware, which from its superiority, finds a ready market east, west, north, and south. The establishment employs about twenty hands in its several departments, and having the best machinery in use, together with two kilns, and experienced and first-class mechanics, it is not only able to produce ware of the best quality, but in unlimited quantity. The clay now being used-recently discovered-produces an article of ware of remarkable stone-like solidity, and is susceptible of a polish and finish almost equal to queensware. With C. R. Collin as President and Treasurer, and M. L. Elliott as Superintendent and Secretary, both energetic and intelligent gentlemen, the Moingona Pottery Works are bound to be successful, both with reference to the articles manufactured and in pecuniary point of view (Boone County Democrat: August 24, 1870).

Over the next few years the Moingona Pottery Works continued to expand its operation and the amount of ware it produced. The quality of ware was not sacrificed for increased

production because the pottery received an award at the State Fair in 1871. The October 3, Boone County Advocate discusses the progress of the Moingona Pottery Works.

The largest amount of business done by any one Pottery, is done by the Moingona Pottery Works. This Pottery is owned and run by a Company, and superintended by C. R. Collin an excellent business man.

This Company employ steam power in their works, having one of C & G. Cooper's best engines, and the improved Ohio Clay Mill. Since the Spring trade began, up to August last, this company manufactured about seventy-six thousand gallons of ware. They employ from 18 to 25 hands, who earn from \$20 to \$80 per month. They employ a splendid corps of mechanics.

This Pottery received the first premium and diploma at the State Fair in 1871 (Boone County Advocate: October 3, 1872).

The success of the Moingona Pottery Works is further documented from a March 4, 1874, account in the Boone County Democrat.

The Moingona Pottery Works are a busy place now-a-days, a full force of men being at work preparing for the spring trade. The ware from these works has achieved an enviable reputation and is demanded all over this and neighboring States. The pottery business is an important item in the industries of Moingona (Boone County Democrat: March 4, 1874).

In June of 1874, a newspaper account said the Moingona Pottery Works was shipping 2000 pounds of ware daily (The Ogden Reporter: June 27, 1874).

On March 24, 1875, George W. Chandler and James Gibson leased the Moingona Pottery Works (Boone County Democrat: March 24, 1875). It is known from Chandler's letters that he

had previously been foreman of the works, except for a time in January of 1875 spent in Galesburg, Illinois selling encyclopedias (Anderson 1974). James Gibson had been travelling agent for the Moingona Pottery Works since April 1873 (Boone County Democrat: April 2, 1873).

G. W. Chandler began working in the Moingona Pottery Works in August of 1869. He previously had worked in a pottery in Middleburg, Ohio (Anderson 1974). On May 19, 1875, James Gibson opened an ice cream and confectionery store in Moingona (Boone County Democrat: May 19, 1875). Some time after this date S. H. Deering became a partner in the Moingona Pottery Works with G. W. Chandler. Chandler and Deering were partners at least from September 13, 1875, through August 22, 1877, judging from dates recorded in their shipping book (Anderson 1974).

S. H. Deering Sylvester H. Deering, like many who worked in the pottery business, was a man of varied occupations. He first worked as a teamster in 1868, at the age of 16, after moving from Maine to Moingona. S. H. Deering's father, Rueban, was a blacksmith and his brother was A. A. Deering, the well-known doctor of Boone County (Iowa Official Census 1870: Vol. 104). S. H. Deering worked in the pottery for two years, beginning in 1870, then attended Mt. Vernon College for one term after which he taught school in Cass township, Boone County for one term (Union Historical Company 1880:633). In

the fall of 1873 Deering entered in the butchering business with his brother-in-law, Luther Hartmen. He continued in this business with the exception of the time between 1875 and 1877 when he was in the pottery business with Chandler. On November 10, 1880, Hartmen bought out Deering and ran the butcher shop himself (Boone County Democrat: November 10, 1880). On December 1, 1880, Deering bought a feed store in Moingona and on January 12, 1881, he moved to Vail, Iowa, and opened his own butcher shop (Boone County Democrat: December 1, 1880; January 12, 1881).

Decline of pottery works Chandler and Deering appear to be the last operators of the Moingona Pottery Works. There were no direct references as to the exact date the pottery closed. However, there were several events that took place which seem to indicate that the Moingona Pottery Works ceased to operate after August or December of 1877. The August or December date is based upon information provided by the personal letters of G. W. Chandler and various newspaper accounts. The first account that the Moingona Pottery Works is not operating is from a newspaper clipping in Mrs. Anderson's possession. Neither the name of the newspaper nor year is indicated in the clipping but it is indicated that the season of the year was winter.

The potteries, that once were active institutions, are not running now, and G. W. Chandler, of the firm of Chandler & Deering, who ran the Moingona Pottery Works, has gone to Ohio, and obtained a situation there, while Mr. Deering has gone back into the meat market (Anderson 1974).

The month and year of the above newspaper account may be determined from letters written by G. W. Chandler to his wife. On December 10, 1877, Chandler was in Middleburg, Ohio, looking for work at the Whitmore, Robinson & Company pottery, he had left his wife and family back in Moingona for the present. He did not get a job until February 2, 1878, as a turner, or thrower, in Springfield, Ohio, four miles from Middleburg. In a letter to his wife and family, Chandler wrote that the stoneware business was very dull at present and the price of ware very low, and this was the reason why he could not find work. On February 11, 1878, Chandler wrote to his wife that he would write to Mr. Blair to see what the prospect was for running the brick pottery in Moingona. The Mr. Blair referred to is probably William Blair who was one of the owners of the Flint Stone Pottery. Blair's role in the pottery business in Moingona will be discussed in the following section on the Flint Stone Pottery. On February 15, 1878, Chandler got a job on a steam power wheel at Johnson & Baldwin's Pottery in Middleburg, Ohio. On April 15, 1878, Chandler wrote to his wife:

I do not know whether the potteries in Moingona will be run this season or not. Mr. Blair said he would let me know if there was any prospect.

May 20, 1878, he wrote to his wife:

. . . if there was anything I could do there [Moingona] to make a living I would gladly come home at any time.

November 4, 1878:

I have no confidence in the ability of Mr. Kelsey to conduct the Pottery business successfully or I would write to him for a job. I have got a pretty good job here and I expect it will be a good deal if I remain here until Spring.

November 11, 1878:

Has Mr. Kelsey commenced running the Pottery yet. I would like to have one of you see Mr. Blair and ask him if Mr. Kelsey will give me employment if I should return home.

The Mr. Kelsey to whom Chandler referred to in his letters could be S. A. Kelsey who operated a pottery in Boonsboro in 1862 (see Figure 2).

February 17, 1879:

Give my respects to Mr. Woodworth, is he still turning the Pottery.

There were no additional references on Woodworth.

There was a network of communication that kept potters informed of where jobs were available. Potters used this network very effectively and often worked at different potteries within a particular region. Evidence of this network among potters in Iowa is shown from the following letter.

On March 24, 1879, E. L. & J. L. Weeks, the operators of the

Des Moines Pottery Works, wrote to G. W. Chandler.

We are informed you have returned from Ohio, and desire a wheel. We want two turners at once and can give you a steady wheel

It is not known if Chandler took the job in Des Moines but on August 18, 1880, Chandler burned a kiln of stoneware in Moingona (Boone County Democrat: August 18, 1880).

Chandler was probably working for William Blair at the Flint Stone Pottery rather than at the Moingona Pottery Works, based on evidence taken from the following newspaper accounts. The first two accounts indicate the Moingona Pottery Works was not in operation.

C. R. Collin, formerly of Moingona, but now a resident of Elgin, Ill., has been here for the past week, and he will open out the old Moingona pottery again (Boone County Democrat: September 15, 1880).

We hear no more about the old pottery starting up, and believe it to be all a hoax (Boone County Democrat: October 20, 1880).

The next reference confirms that G. W. Chandler was operating the Flint Stone Pottery.

The flintstone pottery is running again, under the management of G. W. Chandler (Boone County Democrat: May 18, 1881).

Finally, although the Moingona Pottery Works continued to decline, there were rumors that it would be reopened.

The old Moingona pottery is going to wreck (Boone County Democrat: May 31, 1882).

Old Moingona pottery is to be turned into a tile factory (Boone County Democrat: August 8, 1882).

It is rumored that Mr. Parkhurst will turn his pottery into a tile manufactory (Boone County Democrat: August 29, 1883).

The extent of the deterioration of the pottery can be seen from a letter G. W. Chandler's son, Thaddeus, received from his friend, A. J. Doran, on June 23, 1884. This letter was sent to Des Moines where the Chandler family had moved in April, 1884.

I have got that old wheel borrow, it would not do to put it down to the pottery because it would be stolen before night. The pottery has not got a window or door in it now.

In the 1880 Census only George W. Chandler's name appears related to the pottery business, it gives his age as 48 and his occupation as potter. Neither the 1885 or 1895 Census have any one listed as working in a pottery nor do any of the names previously listed as working in a pottery appear in the Census (Iowa Official Census 1880 & 1895).

The last reference relating to the Moingona Pottery Works is from the transfer records of Boone County. On December 6, 1892, D. M. and G. J. Parkhurst and wife sold the land on which the pottery was located to Phil Livingston. There was no further information on who George J. and D. M. Parkhurst were but assume they were related to the deceased Henry Parkhurst the original owner of the pottery. Phil Livingston was at one time station agent, postmaster and notary public in Moingona (Boone County Transfer Record: Book G).

Flint Stone Pottery (13BN132)

Beginning of pottery The Flint Stone Pottery started out as Atchison & Hutchinson pottery in December of 1870. From newspaper accounts one can follow the early building stages of this pottery operation in Moingona:

Atkinson [sic] & Hutchison [sic] from Lyons, Iowa are building a three story brick pottery at this place. They commenced the brick work last Monday, and their intention is to have the building up and the roof on this week. This will add somewhat to the interest of this place and will be a profitable investment for the parties involved (Boone County Advocate: December 8, 1870).

We learn from Mr. Mauck that the walls of the New [sic] Pottery [sic] at Moingona were carried up to the roof of the building last week. Five persons were only five days laying 60,000 brick (Boone County Advocate: December 15, 1870).

. . . The new pottery is being pushed forward rapidly, and the intention is to have it ready for operation by the 15th of January. The parties interested in the works are making preparations to attach all improved machinery necessary to make it a first class pottery (Boone County Advocate: December 22, 1870).

Issues of the Boone County Advocate were missing between December 22, 1870, and August 15, 1872, making it impossible to follow the later stages of construction and early operation of the Flint Stone Pottery. It was also impossible to check the Boone County Democrat newspaper coverage of the pottery during this time period because issues of the Boone County Democrat were missing from August 24, 1870, to February 26, 1873. The Boone Public Library has on microfilm copies of the

Boone County Advocate from July 5, 1866 to March 13, 1873 and the Boone County Democrat from February 26, 1868 to October 26, 1887, however, the particular issues previously mentioned are not available. The newspaper collection of the State Historical Society of Iowa in Iowa City, Iowa, does not have any copies of the Boone County Advocate and the only copies they have of the Boone County Democrat are from March 3, 1905 to December 28, 1900. These are the only sources that the author knows of that have copies of these two newspapers.

The Atchison involved in the establishment of the Flint Stone Pottery was Oliver C. Atchison, the same man who was the first manager of the Moingona Pottery Works. Atchison and Hutchinson erected the pottery on lots 1 & 4 of block 18 in Moingona (Figure 3). The transactions involving lots 1 & 4 of block 18 are somewhat complicated but are very important because they directly relate to the ownership of the Flint Stone Pottery. The following sequence of events relate to the transactions involving lots 1 and 4 and the Flint Stone Pottery. The information is from the abstract in which these two lots are included, town lot deeds and transfer records, and newspaper accounts.

Transaction involving lots 1 and 4 Lots 1 and 4 of block 18 were platted as "Blair's Addition to Moingona, Iowa" on July 26, 1867, by John I. Blair. On January 12, 1871, John I. Blair entered into a written contract, with Melissa

and Thomas Hutchinson, in which for \$374.00 he would make a general warranty deed to lots 1 and 4 in block 18. Apparently the title gave Blair the power to forfeit the contract for non-payment of the balance of the purchase price. Apparently the first payment of \$9.00 was made leaving a balance of \$365.00. On January 30, 1871, Hutchinson's gave a quit claim deed for the two lots to Oliver C. Atchison. On August 10, 1871, John I. Blair and wife, Ann, gave the Moingona Coal Company a warranty deed to lots 1,2,3,4,5,6, and 8 in block 18. On September 20, 1871, Hutchinson's sold their right to original contract to Oliver C. Atchison for \$400.00. On September 21, 1871, Atchison gave a warranty deed to David Henderson for the undivided halves of lots 1 and 4 of block 18 (Abstract of Title: entries 1-8; and Boone County Transfer Record; Book C: 277-278).

Sometime after this transaction Atchison and Henderson become partners in the pottery business. In August of 1872, an advertisement in the newspaper extolled their ware (Boone County Advocate: August 29, 1872):

Atchison & Henderson
Manufacturers of the

Celebrated Drain Tile,
and all kinds of
Stoneware

Our Drain Tile runs from two to eight inches in diameter, price from 2½ to 12½ cents per foot.

All orders Sent to us
Will be promptly filled

Address Atchison & Henderson
 Moingona, Iowa

Several months later, an article appeared in the Boone County Advocate (October 3, 1872):

Moingona, has another Pottery, run by Atchison & Henderson. This firm does not manufacture on so large a scale as the other but have all the work they can do, and they make splendid ware. The firm are now turning their attention more to the manufacture of tile, and are laying plans for an extensive business in this direction, being already so crowded with orders, that they will be compelled to employ a greater force, in order to be able to supply the demand (Boone County Advocate: October 3, 1872).

In April, 1873, a newspaper advertisement used the name "Flint-Stone Pottery, Atchison & Henderson, Proprietors" (see Figure 5). This is the earliest reference found to the name Flint Stone Pottery. The hyphen does not appear on any of the cobalt blue marked sherds (Figure 16) or on the order form from this pottery (Figure 15).

In 1873 the Moingona Coal Company forfeited the contract, on lots 1 & 4, with Atchison because the balance of the purchase price had not been paid. On February 19, 1874, David Henderson and wife, Jane, gave to John Snedden a warranty deed to the undivided halves of lots 1 and 4. In April, David Henderson became mine inspector for Boone County (Boone County Democrat: April 22, 1874). On February 28, 1874, Atchison sold the right to the contract, to William Blair and Jesse Titman for \$1,500.00, because of the conflict of ownership of

Flint - Stone Pottery,
 (Atchison & Henderson, Proprietors.)
 Moingona, Iowa,
 Manufacturers of
STONEWARE,
Drain Tile,
and Fire Brick.

Our Drain Tile runs from 3 to 8 inches in diameter; price from 2½ to 12½ cents per foot.

Orders promptly filled.

Address
ATCHISON & HENDERSON,
 10+f Moingona, Iowa.

Flint-Stone Pottery
 (Atchison & Henderson, Proprietors)
 Moingona, Iowa,
 Manufacturers of
 Stoneware,
 Drain Tile,
 and Fire Brick.

Our Drain Tile range from 3 to 8 inches in diameter; price from 2½ to 12½ cents per foot.

Orders promptly filled.

Address
 Atchison & Henderson
 10+f Moingona, Iowa.

Figure 5. Advertisement for the Flint Stone Pottery from the Boone County Democrat: April 30, 1873

lots 1 & 4 with the Moingona Coal Company.

William Blair was originally with the firm Blair, Couch & Company in 1868 (Boone County Democrat: September 23, 1868). In June of 1869, William Blair succeeded Henry Parkhurst as agent for the Moingona Coal Company (Montana Standard: June 19, 1869). In 1874, William Blair was a partner in the dry goods and grocery business with Jesse S. Titman (Boone County Democrat: September 30, 1874).

On March 20, 1874, Blair and Titman deposited the unpaid amount on the contract, \$365.00, with the Clerk of the District Court of Boone County, Iowa. They petitioned the court to order John and Ann Blair to deliver a warranty deed for lots 1 and 4, and state that the Moingona Coal Companies claim to said lots is inferior to their claim. John Sneddon also stated that he is the owner of the undivided halves of lots 1 and 4. The Original Notice of Blair & Titman's petition appeared in the Boone County Democrat on April 22, 1874:

Original Notice

To John I. Blair, Ann Blair, and the Moingona Coal Company: You are hereby notified that there is now on file in the office of the clerk of the district court of Boone County, Iowa, a petition of William Blair and Jesse Tietman, [sic] claiming of John I. Blair and Ann Blair a conveyance of lots one and four (1 and 4), in block eighteen (18), in Moingona, Boone county, Iowa, and asking that they be required to make such conveyance, and that all claims of the Moingona Coal Company there to be barred and cut off; said petition also demands costs of suit, and the appointment of a commissioner to make conveyance in case defendants John I. Blair and Ann Blair fail or refuse to make such conveyance.

And unless you appear and defend thereto on or before noon of the second day of the next May term of the district court of Boone County, Iowa, to be begun and held at the court house in Boonsboro, Iowa, on the fourth Tuesday and 26th day of May, 1874, your default will be entered and judgement will be rendered against you thereon.

HULL & RAMSEY

Attorneys for Plaintiffs

(Boone County Democrat: April 22, 1874).

In September 1876, Blair & Titman dissolved partnership (Boone County Democrat: September 13, 1876). In April 1877, the District Court ruled in favor of John I. Blair and the Moingona Coal Company. The suit finally reached the Supreme Court in June 1878, and they overturned the lower court ruling.

On October 4, 1878, the lower court carried out the Supreme Court ruling, and gave title to Blair & Titman for half of the undivided lots 1 & 4 and gave John Snedden the other half of said lots. However, Snedden's title depended upon liens of Blair & Titman. The court also ordered that the Moingona Coal Company had forty days in which to deliver a general warranty deed to Blair & Titman and John Snedden. If the deed was not delivered a commissioner, John Hazlett, would be appointed to make and deliver a deed.

On July 26, 1879, Snedden's undivided half of lots 1 and 4 were sold at a sheriff's sale. Notice of the sale appeared in the Boone County Democrat on July 2, 1879.

judgment and increase costs. (Boone County Democrat: July 2, 1879).

Since the Moingona Coal Company failed to deliver a warranty deed to Blair, Titman and Snedden, the court of Boone County appointed a commissioner to make and execute a deed. The court appointed James Hazlett commissioner and on August 12, 1879, a Commissioner's deed was made giving Blair & Titman half of the undivided lots 1 & 4, and John Snedden the other half of the undivided lots 1 & 4 (Abstract of Title entry 20 and Town Lot Deed 1879; Book 11, p. 587).

Close of pottery between 1874-1879 Because of the court case it appears that the Flint Stone Pottery was not in operation from 1874 to 1879 because the question of ownership of the land, and thereby the pottery, had not been settled. At the time of the court case the pottery was valued at five thousand dollars (Boone County Democrat: April 24, 1873). There are some questions as to which years the Moingona potteries are in operation. Newspaper accounts do not always indicate which pottery they are referring to. Because of this problem it will be necessary to jump back and forth between the accounts of the Moingona Pottery Works and the Flint Stone Pottery in order to determine which pottery the newspapers are referring to. The following discussion will present evidence to support the contention that the Flint Stone Pottery was not operating from 1874 to 1880.

There are the previously cited letters from G. W. Chandler who was working in Middleburg, Ohio and wrote to his wife in Moingona, that seem to indicate that the potteries in Moingona are not in operation in 1878 and 1879. An indication that the Flint Stone Pottery was not running in 1876 is taken from the shipping book of Chandler & Deering (Moingona Pottery Works) for the period from 1875 to 1877. In this shipping book are orders for Blair & Titman, the owners of the Flint Stone Pottery. The orders are on May 19, 25, and 26, 1876; October 27, 1876; and December 13, 1876. This seems to indicate that the Flint Stone Pottery was not in operation and that the Moingona Pottery Works were filling orders for them (Anderson 1974). If this is not the case and the Flint Stone Pottery was running, why would the owners of the Flint Stone Pottery have orders filled for them by the rival Moingona Pottery Works? Blair & Titman do not appear to have had any previous experience in the pottery business when they acquired ownership of the Flint Stone Pottery in 1874. This was the year that the suit was brought to court over the ownership of lots 1 & 4, on which the pottery was located. It was not until 1879 that Blair & Titman finally received a deed to lots 1 & 4. Between 1874 and 1879 the Moingona Coal Company had legal title to these lots, and therefore the pottery built on them. It is questionable if the defendants (Moingona Coal Company) in the suit over ownership of the land would have

allowed the plaintiffs (Blair & Titman) to operate the Flint Stone Pottery. The Flint Stone Pottery probably continued to receive orders for ware during this time and these orders were filled by Chandler & Deering of the Moingona Pottery Works.

Reopening of pottery It was probably sometime after the sheriff's sale on July 2, 1879, that the Flint Stone Pottery went back into operation. G. W. Chandler had returned from Ohio by March of 1879. An article in the Boone County Democrat (August 18, 1880) reported that Chandler burned another kiln of stoneware in August, 1880. In September of 1880, the Boone County Democrat (September 15, 1880) listed the names of the business men in Moingona, these included: William Blair was in groceries and G. W. Chandler in crockery ware. The newspaper article also noted that:

C. R. Collin, formerly of Moingona, but now a resident of Elgin, Ill., has been here for the past week, and he will open out the old Moingona pottery again (Boone County Democrat: September 15, 1880).

The reference to Collin seems to indicate that it was the Moingona Pottery Works that he intended to reopen. In October of 1880 there are two references that seem to indicate Chandler was working for William Blair:

G. W. Chandler burned another kiln of stoneware last week and it looks good (Boone County Democrat: October 6, 1880).

G. W. Chandler has burned another kiln of stoneware for William Blair (Boone County Democrat: October 27, 1880).

In May of 1881 we have a definite indication Chandler is operating the Flint Stone Pottery:

The flintstone pottery is running again, under the management of G. W. Chandler (Boone County Democrat: May 18, 1881).

It is possible that this statement meant that the pottery was reopening after having been closed during the court case. If this is the case, then the previous references to Chandler burning a kiln would indicate that he was working at the Moingona Pottery Works and filling Blair's orders there because the Flint Stone Pottery was closed. However, this is probably not the case for the reasons already discussed.

In January 1881 William Blair opened a store in Coaltown (Angus) but also kept his store in Moingona (Boone County Democrat: January 26, 1881; May 4, 1881). In June the following article appeared indicating Chandler was still working at the Flint Stone Pottery:

W. Chandler, our fancy potteryman, is talking of making clay balls instead of glass balls for our & other sportsmen to shoot at (Boone County Democrat: June 8, 1881).

Network of communication among potteries The next reference to the Flint Stone Pottery is from a letter Chandler received in December of 1881. This letter is important because it shows the informal organization of the potteries in Iowa and their attempt to set uniform prices for their ware.

On December 31, 1881, Chandler received a post card from E. L. & J. L. Weeks of the Des Moines Pottery Works stating that:

We agree with you that raise should be general
There will probably be a convention called at an
early day in order to better confer together and
get the matter up in good shape. We have heard
from Boone, Ft. Dodge, Eldora, Cedar Falls,
Fairport, Muscatine, and Bonaparte, all favorable.
Will write you again soon. (Anderson 1974).

A second letter, dated January 14, 1882, to G. W. Chandler from E. L. & J. L. Weeks includes the following discussion on the prices of ware:

After corresponding with the Iowa Potteries we find there is a unanimous desire to get a raise on all kinds of ware. We have drawn up a circular which in order to get the matter started the 3 potteries here in Des Moines have signed. This makes price of Hollow ware $7\frac{1}{2}\text{¢}$, jugs 9¢ which we believe will meet approbations of all. Please sign and return by first mail so we may get circulars printed and sent out to the merchants before Spring trade begins to open.

Please see Mr. Blair and have him sign also.
(Anderson 1974).

On January 25, 1882, the circular was printed and sent out (see Figure 6). This circular is particularly significant in that it reflects the communication network that existed among the Iowa potteries in the late nineteenth century. This network also extended to potteries in other states. The following list of names represents correspondence with potteries that Chandler received from 1858 to 1897 concerning inquiries about employment:

TO THE TRADE.

It is well known that, for several years past, stoneware has been sold extremely low. So small has been the margin to the manufacturer, that the increase cost of making, through great advance in coal, wood and labor, has cut off all the profits, and compelled us to sell our products barely at cost. In order that the sale of stoneware may afford a profit equal, at least, with that of other staple goods, we, the undersigned, stoneware manufacturers, do hereby agree that we will from this date, January 25, 1882, make the following prices: Butter Pots, Pickle Jars, Churns and Milk Pans, seven and one-half cents (7½) per gallon; Jugs nine cents (9) per gallon.

Very respectfully yours,

E. L. & J. L. WEEKS, Des Moines, Iowa.
 E. C. UPDIKE, Des Moines, Iowa.
 GEO. EMERLING, Des Moines, Iowa.
 SCHLETTER BROS., Boone, Iowa.
 M. W. GRIFFEE, Boonesboro, Iowa.
 MUSCATINE STONEWARE CO., Muscatine, Iowa.
 HANBACK & WILSON, Bonaparte, Iowa.
 G. W. CHANDLER, Moingona, Iowa.
 W. BLAIR, Moingona, Iowa.
 W. B. SHERWOOD & Co., Cedar Falls, Iowa.
 JOHN ROAB & SON, Cedar Falls, Iowa.
 H. C. SWEET, Eldora, Iowa.
 C. W. & G. H. TOLMAN, Eldora, Iowa.

Figure 6. January 25, 1882, price circular of ware of Iowa potteries (Anderson 1974)

YEAR	NAME	PLACE
1858	James Macumber	Arrow Rock, Missouri
1859	G. N. & G. W. Ebey	Winchester, Illinois
1859	James Brat	Mound City, Illinois
1859	William Keller	New Albany
1861	George & Shoemaker	Smokey Ridge, Ohio
1862	T. S. Balsley	Detroit Pottery, Michigan
1865	F. R. Miller	Sugar Grove, Pa.
1868	A & F Hoberecht	California, Missouri
1868	Nicholas Luer	Booneville, Missouri
1868	John Kingsbury	Utica, Illinois
1868	Wm. Maharr	Peoria, Illinois
1878	Whitmore, Robinson & Co.	Middleburg, Ohio
1878	Johnson & Baldwin's Pottery	Middleburg, Ohio
1882	E. L. & J. L. Weeks	Des Moines Pottery Works
1882	M. White	Union Pottery Works (Ft. Dodge)
1883	E. C. Updike	Eagle Pottery Works (Des Moines)
1883	D. L. Eaton	Lincoln, Nebraska
1883	L. K. Force	Akron Stoneware Co.
1883	Polk & Company	Louisville, Nebraska
1883	J. H. Rick	Red Wing Stoneware Co.
1896	Wm. Hanna	Monmouth Pottery Co. (Illinois)
1897	Pres. W. G. White V.P. E. Hartwell Tres. H. M. White Sec. W. G. Moore	Ft. Dodge Stoneware Co.

(Anderson 1974).

This network of communication provided a means of disseminating information concerning such things as; setting up price scales, pottery equipment for sale, and inquiries about employment, both positions open and positions wanted.

Final closing of pottery The following discussion presents evidence for the date of the final closing of the Flint Stone Pottery. On April 10, 1882, Chandler received a positive reply from M. White of the Union Pottery Works in Ft. Dodge in response to Chandler's inquiry about a job there.

Apparently Chandler did not take the job because on April 17, 1882, he is requested by William Blair to fill an order received from a Parks & Leaming (Anderson 1974). Towards the end of July, 1882, Blair moved his dry goods and grocery store to Coaltown (Boone County Democrat: May 31, 1882; August 2, 1882). Shortly thereafter a newspaper account states:

G.W. Chandler burned a kiln of stoneware one day last week (Boone County Democrat: August 8, 1882).

It appears that Chandler continued to operate the Flint Stone Pottery for a short while after Blair moved. An article in the Boone County Democrat (March 14, 1883) reported that William Blair wanted to sell out in Angus (Coaltown) and move back to Moingona. This move does not seem to be related to the Flint Stone Pottery because on March 27, 1883, Chandler wrote to his wife from Des Moines where he was working for the Eagle Pottery (Anderson 1974). In addition no potteries are listed among businesses in Moingona in an article in the Boone County Democrat (May 9, 1883).

G.W. Chandler is the last known operator of the Flint Stone Pottery and there is no evidence, either in his personal letters or in newspaper accounts, that he worked there after working in Des Moines at the Eagle Pottery. On May 2, 1883, Chandler wrote to his wife from Fort Dodge where he was working at the Union Pottery Works. This is confirmed by newspaper accounts:

G.W. Chandler has gone to Fort Dodge to work in White's pottery, and will remove his family there shortly (Boone County Democrat: June 6, 1883).

G. W. Chandler, who has been employed in the Fort Dodge pottery works in that city, has returned to this place, and is thinking of going to Des Moines (Boone County Democrat: July 25, 1883).

On June 15, 1883, Chandler received a letter from J. F. Polk & Company of Louisville, Nebraska, inquiring about a second hand, clay picker Chandler had for sale. January 9, 1884, a man in Booneville, Missouri, asked about the same clay picker (Anderson 1974). These two inquiries may refer to equipment from the Flint Stone Pottery. On April 2, 1884, Chandler had his household goods sent to Des Moines (Anderson 1974). On September 23, 1885, William Blair moved to Oskaloosa, Iowa (Boone County Democrat: September 23, 1885).

There is one final reference to a pottery in Moingona, taken from the Moingona town council meeting minutes, on April 10, 1885. A motion was carried to raise the tax value on the pottery works from \$100.00 to \$200.00 (Kennedy 1974 from Moingona town council meeting minutes). The reference does not indicate the pottery in question or if it is operating. Both potteries in Moingona appear to be closed at this date, as has been previously discussed. The increase in taxes probably resulted from a higher appraised value of either the buildings and/or land. The increase would not necessarily depend upon whether the pottery was in operation. There were no references to the potteries in Moingona from newspaper accounts from 1884 through 1887.

Finally on December 10, 1891, the land on which the Flint Stone Pottery was located was sold as a tax deed by the Treasury of Boone County. It was sold for taxes for the years 1885 through 1890, to Andrew McLead a grocer in Moingona (Abstract of Title entry 21:1974; Town Lot Deed 1895; Book T.D.3, p. 101).

Summary of Moingona potteries

The picture of the pottery industry in Moingona is complicated because there is so much overlap among the workers and owners of the two pottery works. Furthermore, the accounts from newspapers and other archival data are not always as clear as one would like. A brief summary of the previous information is as follows.

First, the Moingona Pottery Works seems to have been in operation from 1869 through 1877, a period of eight years.

Second, the Flint Stone Pottery operated from 1871 to 1874, when the court case came up.

Third, from 1874 to 1879 it seems that the Flint Stone Pottery was not in operation but the evidence is incomplete.

Fourth, the Flint Stone Pottery appears to have reopened and operated from 1879 to 1883, or corresponding to the dates G. W. Chandler returned to Moingona from Ohio, until he left again to work in the pottery in Fort Dodge. If this is the case the Flint Stone Pottery was in operation a total of seven

years; three years between 1871 and 1874 and another four years from 1879 to 1883.

Pottery Manufacturing Processes at Moingona

The following section will discuss the processes involved in the manufacture of pottery during the late nineteenth century in the midwest. The sources of data included newspaper accounts, primarily an article from the December 11, 1869, Montana Standard, personal letters of G. W. Chandler, and literature on pottery manufacturing. In many cases the exact manufacturing process is not known for the Moingona potteries, therefore information is provided on the most likely method used by nineteenth century potteries in the midwest region. An example is the information on the use of the jigger and jolly, it was not directly stated in the archival material that these machines were used at the Moingona potteries. However, the archival data did mention that molds were used and the jigger and jolly are the most common equipment used with molds. Other items such as an adjustable pot gauge, shaving tools, and ribs have been included in this discussion because they are common pottery manufacturing equipment. There is no direct references to this equipment in the archival data related specifically to the Moingona potteries, nevertheless, they were probably used at both potteries. The archaeological residue also provided evidence that many of these tools were

used. For example, the cobalt blue designs found on crock and churn sherds indicate that a slip trailer was used to apply the cobalt blue. Also the similarity in many of the rim sherds indicate profile ribs may have been used (see Figure 7b, 7c).

This section discusses the processes of pottery manufacture beginning with mining of the clay, through construction of the ware, and finally sale of the finished product.

Preparing the clay

The first step in preparing the clay was the mining or digging of clay. The clay could often be acquired from veins or drifts located on the sides of bluffs, the Moingona Pottery Works got their clay in this way (Montana Standard: November 27, 1869). The clay had the consistency of soft stone when it was first taken out. From the drifts the clay was taken to the pottery where it was piled up and soaked in water for about two days until it was softened into a workable state (Montana Standard: December 11, 1869). It was then ground in a clay grinding mill or picker, probably steam powered; (Boone County Advocate: October 3, 1872) this removed impurities such as large stones. Further impurities are removed by a process of wedging or kneading the clay by hand and picking out the stones. The wedging also works the air out of the clay. The clay was then weighed out in balls corresponding to the various sizes of ware that would be made (Montana Standard: December

11, 1869). This job was often done by young boys sometimes referred to as ball makers (Anderson 1974: February 10, 1879; April 12, 1897).

Shaping the ware

Jigger and jolly Plates, milk pans or bowls, cups, flower pots and other types of short sided or open mouthed vessels may have been molded in plaster of Paris molds (Montana Standard: December 11, 1869) and shaped by a jigger and jolly. Jiggering refers to the process of shaping the outside of a vessel while jollying refers to shaping the inside of a vessel. The machine that is used for the shaping is called a jigger and jolly. This machine consists of a vertical spindle carrying a head, which holds a plaster mold, and causes it to rotate; and a counterbalanced lever arm carrying a template or profile which when brought into contact with the clay in the mold shapes the vessel. The shape of the vessel will depend upon whether an inside or outside mold and profile are used (Figure 7).

For large scale operations separate machines were probably used, one for jiggering and another for jollying, rather than continually changing the profiles. Using molds and the jigger/jolly is much quicker than throwing on a wheel, requires less skill, and creates more uniform shaped ware.

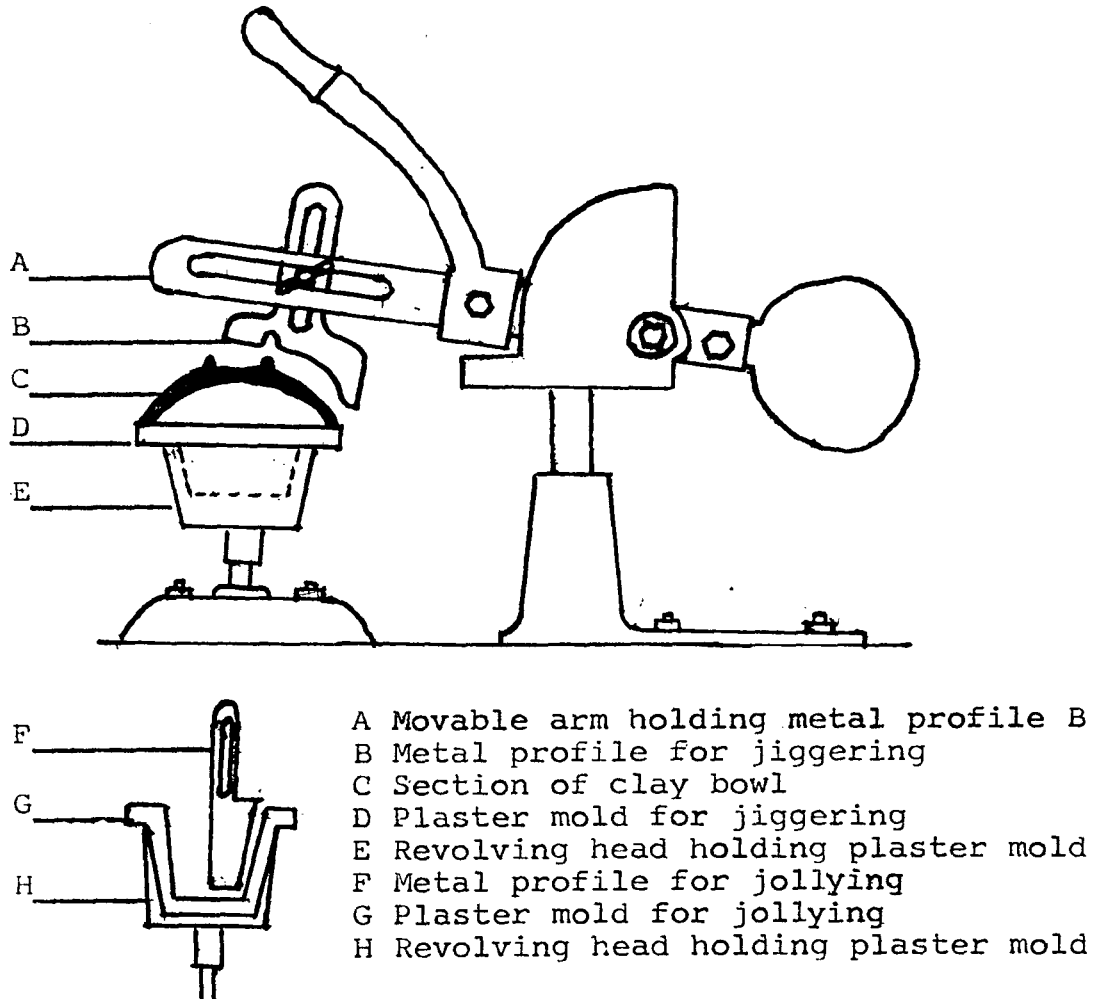

Figure 7. Jigger and jolly (Billington 1962:101)

The disadvantages of it are that the plaster molds are expensive and they wear out rapidly. Because thinner clay is used there is a greater tendency of cracking and warping of the ware (Searle 1929:224-227).

Throwing Vessels such as jugs, jars, crocks, and pitchers were thrown on a potter's wheel (see Plate 2). The potter's wheel was turned by the motion of the potter's foot on an iron fly wheel attached to the lower part of the potter's wheel (Montana Standard: December 11, 1869). This flywheel was connected by a vertical shaft to a disc of heavy wood or iron on which the clay was thrown. On the revolving disc the thrower placed a ball of clay, pushing it firmly down till it stuck fast to the disc. Using water to moisten the surface and to allow his hands to slide easily, the thrower made a hole in the center of the ball of clay and pulled up the walls to the required height. During this process his hands were opposite each other, one on the inside and the other on the outside of the vessel (Montana Standard: December 11, 1869). Looking at body sherds from the two potteries you can see these finger impressions in the form of slight ridges. Where a neck is required, for example jugs, the top part of the walls were brought gradually together (Montana Standard: December 11, 1869). Sometimes adjustable hinged pointers for measuring width and height were attached to the throwing wheel as an aid for producing repeated identical shapes (Figure 8). While the

vessel is revolved on the wheel various flat profile tools known as "ribs" can be used for clearing away soft clay and smoothing away knuckle ridges (Figure 8). Ribs were generally made out of wood and were about $4\frac{1}{2}$ inches long and $\frac{1}{2}$ inch thick, with a hole in the center to provide a grip for thumb and finger. A profile type of rib could also be used for shaping the rim of a vessel while it was being thrown (Binns 1967:70-75; Billington 1962:68-74; Webster 1971:27). A rib similar to the one shown in Figure 8B was found with G. W. Chandler's potter's wheel.

After the vessel had been thrown to its final height it was cut from the disc with a fine wire, handles could then be attached or stamp impressions made in the moist clay (Montana Standard: December 11, 1869).

Drying the ware Before the ware could be decorated with glaze or slip, it had to be partially dried first. After the ware was taken off the wheel it was set upon a long shelf over an oven or drier. The drier was a long flat-topped flue with a fire burning at the outer end, making a mild heat through the flue. The vessels stood on the shelves about twelve hours, until they were hard enough to handle for turning, glazing and slipping (Montana Standard: December 11, 1869).

Turning the ware The trimming or smoothing of a thrown vessel after it has partially dried is referred to as turning. The terms thrown and turned were often used as a

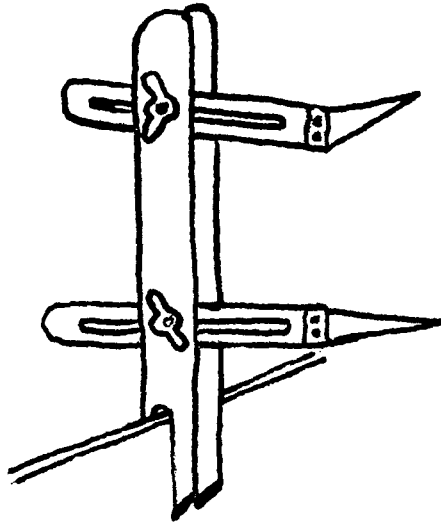

A Adjustable Pot Gauge

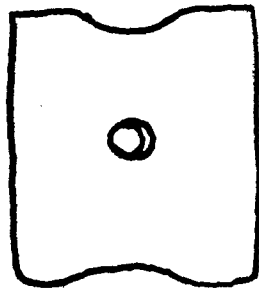

B Rib



C Profile Rib

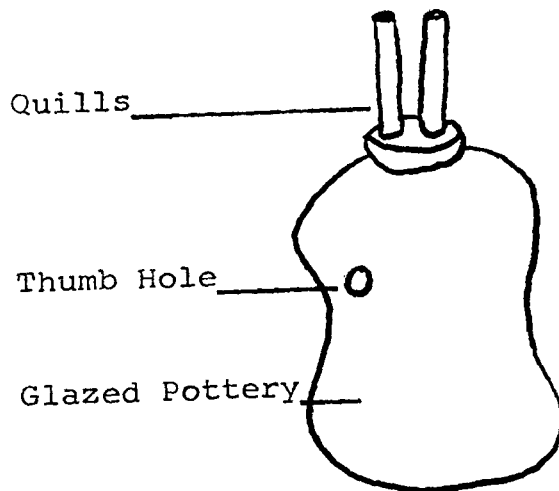

D Slip Trailer

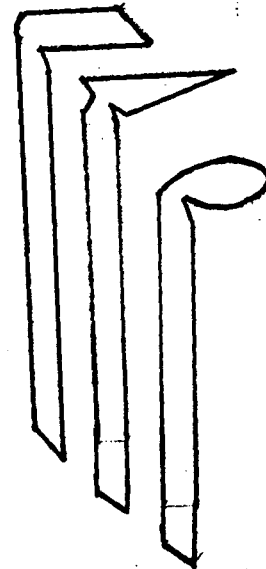

E Shaving Tools

Figure 8. Potter's tools (Leach 1940:82,83,112)

single operation although it was often the work of two men (Binns 1967:70). After the ware had dried to a "leather hard" condition the shaping or trimming, especially the base of the vessel, can be done by means of a lathe, similar to the process used for shaping wood or metal, or it can be done on the potter's wheel. If the wheel is used the ware is fixed upside down to the wheel by pieces of moist clay. The hollow metal heads of the jigger/jolly can also be used to hold the vessel, using clay as padding (Billington 1962:68-69). The turning equipment consists of a board support, a turning stick and a set of tools. The board about 8 inches wide and two feet high is set upright at the back of the wheel opposite the workman, and is used to support the turning stick. The stick, such as a broomhandle, has a nail in one end which is pressed into the board. The stick is held in the left hand while the right hand, holding the tool, is rested on the stick (Binns 1967:71). The shaving tools are made of hoop-iron bent at the ends and filed into various angles and curves (Figure 8). These tools must be kept sharp so that they will cut cleanly rather than tear the clay (Billington 1962:69-70). After the equipment has been set up the vessel can be revolved on the wheel and trimmed to the required shape. After the vessel had been turned it was stored until a sufficient amount had accrued to fill the kiln, at which time the slipping and blueing would be done (Montana Standard: December 11, 1869).

Slipping and blueing the ware After the dried ware was placed in the storeroom the process of slipping and blueing took place. Slip was placed on the interior or exterior surface of the vessel to give a different color or texture to the ware. The main slip used was called "Albany slip" and produced a reddish brown color. It was placed on the outside of milk pans and jugs and on the inside of crocks and jars. The clay used for this slip was found only in New York state and was shipped to the potteries (Montana Standard: December 11, 1869). Albany slip could also have been locally produced. Mary Miller, a potter from Boone, Iowa, has duplicated fairly accurately a brown slip similar to Albany made from local Boone County clays. The process of applying the Albany slip was to mix the clay with water until the mixture had the consistency of cream. Then by means of a pump set in a vat of slip the inside of the vessel was sprayed with slip. Jugs which were coated on the outside were dipped into the vat. When these slipped vessels were placed in the kiln for firing it was important that the slipped surfaces be placed inside something else or the effect of the heat would cause a very black finish (Montana Standard: December 11, 1869).

The other process done in the storeroom is called blueing or decorating the pottery with cobalt blue. This process is done by hand by a "bluer" (Montana Standard: December 11, 1869). Blueing is a form of underglazing in which the darker

blue color is applied to the body of the ware which is then salt glazed during the process of firing. The cobalt blue could be placed on a vessel by means of a metal stencil, which was usually the case for numbers or the names of the potters or pottery. For freehand decorating the cobalt blue was put on the vessel in much the same way that a cake is decorated with icing. The blueing was applied by means of a slip trailer, a clay vessel with a narrow neck in which a cork with one or more quills were fitted. There was a thumb hole or opening on one side of the trailer by which the bluer could control the flow of blueing or slip, a drawing of a slip trailer is shown in Figure 8 (Leach 1940:112). Using this trailer the bluer marked by eye the outline of the design and rapidly trailed it onto the vessel. The blue marks soon dried and the ware was then ready for the final step, the burning in the kiln, which also fixed the color (Montana Standard: December 11, 1869).

Firing or burning the ware After enough decorated and slipped ware was accumulated it was taken from the storeroom to be stacked in the kiln and fired. The kiln was a large egg shaped oven with the top contracting to a small aperture to make a draft to the fire (Montana Standard: December 11, 1869). Harold F. Guiland (1971: 49) provides a generalized description of nineteenth century kilns:

After the Civil War most of the larger commercial stoneware potteries were using kilns similar in design to that of the cupola ovens or common potter ovens used in England. They were round, updraft kilns with a stacking chamber about ten feet in diameter and eight feet high. A steep, conical stack erected on top of the kiln walls enclosing the arch carried the exhaust gases up through the roof of the pottery (Guilland 1971:49).

The ware occupied only a small part of the kiln, the lower part of the kiln being firing chamber and the upper part of the kiln was an open chimney stack. Firing was a delicate operation and a mistake could ruin an entire kiln of ware. The first step in firing was setting of the ware. The ware must be set in the kiln perfectly perpendicular, one piece on another with no tendency to incline or the ware would warp and bend when heated (Montana Standard: December 11, 1869). Pieces of moist clay, which could be called "kiln furniture", were used to insure that they remained upright during the firing. The wares that had been "slipped" on the inside were turned bottom upwards, having within each a smaller vessel "slipped" on the outside. This was to make sure no "slipped" surface was exposed to the salt fumes. The firing continued for about forty-eight hours, during which time the fires had to be carefully watched so that there was not a greater heat in some portions of the kiln than in others in order to prevent the ware from melting or inclining (Montana Standard: December 11, 1869).

Salt glazing the ware At the close of the second day of firing a quantity of rock salt was thrown into the firing chamber through port holes on the side, about 70 pounds of salt per 3,000 gallons of ware was used (Montana Standard: December 11, 1869). This is what was referred to as "salt glazing." The salt volatilizes into a vapor and combines with the free silica in the clay body, covering the ware with a thin mottled glaze and giving the vessel a polished stone appearance (Guilland 1971:57). The salt glaze has an orange peel texture and can vary in color from gray, tan, to brown. Because the salt would adhere to any surface that was exposed it was necessary that the Albany slipped vessels be protected in the manner discussed in the section on slipping the ware. The only ware that was not glazed or slipped was that which was to remain porous, i.e. bisque, such as flower pots.

After the glazing had taken place the kiln was closed entirely, except at the chimney top, and was allowed to cool gradually for about three days. If the cooling process was too sudden or too slow the ware might have cracked and burst. After the kiln had cooled down, the ware was ready for sale or delivery (Montana Standard: December 11, 1869).

Selling the ware Orders could be placed for the various wares on paper forms that listed the types and sizes of ware manufactured by the Moingona potteries. Orders were also written on letters to the potteries or were taken by

travelling agents employed by the potteries. Ware that was not specified on the forms could be made to order. These order forms are important because they provide information about terminology related to the wares. This terminology is very useful in determining the functional vessel categories of the archaeological remains. The archaeological analysis can also be aided by comparing the differences in sizes of ware between the two Moingona potteries. The order forms also provided information on who leased or operated the potteries.

Examples of the various order forms are given in Figures 9 through 14, the first four are from the Moingona Pottery Works and the last one from the Flint Stone Pottery.

There were three order forms from the Moingona Pottery Works. The first form is from the period when C. R. Collin was lessee of the Moingona Pottery Works and was a single piece of paper which listed the types of ware made but did not give the various sizes of the ware. An example of this type is shown in Figure 9.

Newspaper accounts indicate that G. W. Chandler & S. H. Deering were the successors to C. R. Collin and this is verified by an order form with their names on it. The form shown in Figure 10 used by Chandler & Deering is basically the same as the one used by C. R. Collin except that pitchers and vases are not included on it. This may indicate that they were not made as a regular item at that time by the Moingona Pottery

No. Butter Pots Churns & Cows. Pans. Jugs. Preserve Jars. Fruit Jars. Flower Pots. Pitchers. Bean Pots. Spittoons. Chambers. Water Coolers. Vases. Hanging Baskets	FROM MOINGONA POTTERY WORKS, <i>C. R. COLLIN, Lessee.</i> MOINGONA, BOONE COUNTY, IOWA.
	<hr/> <i>For Messrs.</i> _____ <hr/> <hr/>
	<i>No. Pieces</i> _____ <i>Pounds</i> _____

Figure 9. Moingona Pottery Works order form (Anderson 1974)

No. Butter Pots. Churns & Covers. Pans. Jugs. Preserve Jars. Fruit Jars. Flower Pots. Bean Pots. Spittoons. Cham bers. Water Coolers. Hanging Baskets.	FROM CHANDLER & DEERING, MOINGONA POTTERY WORKS, MOINGONA, BOONE COUNTY, IOWA.
	<hr/> <i>For Messrs.</i> _____ <hr/> <hr/>
	<i>No. Pieces</i> _____ <i>Pounds</i> _____

Figure 10. Moingona Pottery Works order form (Anderson 1974)

Works.

There is a more elaborate form used by Chandler and Deering that consisted of a folded sheet of paper (Figures 11 and 12). This order form broke down the various types of ware into the sizes available and was probably used later than the order form shown in Figure 10. This order form can also be dated to the 1870's because of the number 187 that appears below Moingona Boone Co., Iowa, on the front page of the form. A space is left after the 7 to fill in the exact year the order was made. Examples of this form were also found in which orders had been made and the date was filled in. Another indication of the time period this form was used came from information given on the front page of the form. On this page it states that a diploma and first premium were awarded to the Moingona Pottery Works for their ware at the Iowa State Fairs of 1871 and 1872. Finally the shipping book used by Chandler & Deering is dated from 1875 to 1877 which further narrows down the time period these order forms were used. Comparing the three order forms from the Moingona Pottery Works we find that: pitchers and vases are listed on the form shown in Figure 9 but are not listed on forms shown in Figures 10 and 11; spittoons, water coolers, butter pots, and bean pots are listed on forms shown in Figures 9 and 10 but are not listed on the form shown in Figure 12. However, the pots listed on Figure 12 may be the same butter or bean pots listed on the

<p>GOODS OF ANY DESCRIPTION <small>NOT SPECIFIED</small> Made to Order on Short Notice.</p> <hr/> <p><i>Yours Truly,</i></p> <p style="text-align: center;"></p>	<p>CHANDLER & DEERING, <small>(Successors to C. R. Collin.)</small></p> <p>Moingona Pottery Works, <small>MANUFACTURERS OF ALL KINDS OF</small> STONEWARE.</p> <hr/> <p><small>Diploma and First Premium Awarded at Iowa State Fairs of 1871 and 1872.</small></p> <p><i>Moingona Boone Co., Iowa,</i> } } 187</p> <p><i>Mc</i>.....</p> <p><i>Herewith please find list of goods manufactured by us, in the form of an order.</i></p> <p style="text-align: right;"><i>Yours Truly,</i> CHANDLER & DEERING.</p>
---	--

Figure 11. Outside pages of Moingona Pottery Works order form (Anderson 1974)

<p style="text-align: center;"><i>187</i></p> <p>CHANDLER & DEERING, Moingona Pottery Works, Moingona, Iowa.</p> <p>GENTS--Ship us the Following Goods: <i>Terms.....Days.</i></p> <table border="1" style="width: 100%; border-collapse: collapse;"> <tr> <td style="width: 10%; padding: 5px;">Pieces</td> <td style="padding: 5px;">6 Gallon Pots.</td> </tr> <tr> <td style="padding: 5px;"></td> <td style="padding: 5px;">5 Gallon Pots.</td> </tr> <tr> <td style="padding: 5px;"></td> <td style="padding: 5px;">4 Gallon Pots.</td> </tr> <tr> <td style="padding: 5px;"></td> <td style="padding: 5px;">3 Gallon Pots.</td> </tr> <tr> <td style="padding: 5px;"></td> <td style="padding: 5px;">2 Gallon Pots.</td> </tr> <tr> <td style="padding: 5px;"></td> <td style="padding: 5px;">1 Gallon Pots.</td> </tr> <tr> <td style="padding: 5px;"></td> <td style="padding: 5px;">½ Gallon Pots.</td> </tr> <tr> <td style="padding: 5px;"></td> <td style="padding: 5px;">6 Gallon Pot Covers.</td> </tr> <tr> <td style="padding: 5px;"></td> <td style="padding: 5px;">5 Gallon Pot Covers.</td> </tr> <tr> <td style="padding: 5px;"></td> <td style="padding: 5px;">4 Gallon Pot Covers.</td> </tr> <tr> <td style="padding: 5px;"></td> <td style="padding: 5px;">3 Gallon Pot Covers.</td> </tr> <tr> <td style="padding: 5px;"></td> <td style="padding: 5px;">2 Gallon Pot Covers.</td> </tr> <tr> <td style="padding: 5px;"></td> <td style="padding: 5px;">1 Gallon Pot Covers.</td> </tr> <tr> <td style="padding: 5px;"></td> <td style="padding: 5px;">6 Gall. Churns with.....covers</td> </tr> </table>	Pieces	6 Gallon Pots.		5 Gallon Pots.		4 Gallon Pots.		3 Gallon Pots.		2 Gallon Pots.		1 Gallon Pots.		½ Gallon Pots.		6 Gallon Pot Covers.		5 Gallon Pot Covers.		4 Gallon Pot Covers.		3 Gallon Pot Covers.		2 Gallon Pot Covers.		1 Gallon Pot Covers.		6 Gall. Churns with.....covers	<table border="1" style="width: 100%; border-collapse: collapse;"> <tr> <td style="width: 10%; padding: 5px;">Pieces.</td> <td style="padding: 5px;">5 Gall. Churns with.....covers</td> </tr> <tr> <td style="padding: 5px;"></td> <td style="padding: 5px;">4 Gall. Churns with.....covers</td> </tr> <tr> <td style="padding: 5px;"></td> <td style="padding: 5px;">3 Gall. Churns with.....covers</td> </tr> <tr> <td style="padding: 5px;"></td> <td style="padding: 5px;">1 Gallon Milk Pans.</td> </tr> <tr> <td style="padding: 5px;"></td> <td style="padding: 5px;">½ Gallon Milk Pans.</td> </tr> <tr> <td style="padding: 5px;"></td> <td style="padding: 5px;">2 Gallon Jugs.</td> </tr> <tr> <td style="padding: 5px;"></td> <td style="padding: 5px;">1 Gallon Jugs.</td> </tr> <tr> <td style="padding: 5px;"></td> <td style="padding: 5px;">½ Gallon Jugs.</td> </tr> <tr> <td style="padding: 5px;"></td> <td style="padding: 5px;">2 Gallon Preserve Jars.</td> </tr> <tr> <td style="padding: 5px;"></td> <td style="padding: 5px;">1 Gallon Preserve Jars.</td> </tr> <tr> <td style="padding: 5px;"></td> <td style="padding: 5px;">1 Gallon Fruit Jars.</td> </tr> <tr> <td style="padding: 5px;"></td> <td style="padding: 5px;">½ Gallon Fruit Jars.</td> </tr> <tr> <td style="padding: 5px;"></td> <td style="padding: 5px;">1 Gallon Flower Pots.</td> </tr> <tr> <td style="padding: 5px;"></td> <td style="padding: 5px;">½ Gallon Flower Pots.</td> </tr> <tr> <td style="padding: 5px;"></td> <td style="padding: 5px;">¼ Gallon Flower Pots.</td> </tr> <tr> <td style="padding: 5px;"></td> <td style="padding: 5px;">Hanging Flower Baskets, large</td> </tr> <tr> <td style="padding: 5px;"></td> <td style="padding: 5px;">" " " small</td> </tr> </table>	Pieces.	5 Gall. Churns with.....covers		4 Gall. Churns with.....covers		3 Gall. Churns with.....covers		1 Gallon Milk Pans.		½ Gallon Milk Pans.		2 Gallon Jugs.		1 Gallon Jugs.		½ Gallon Jugs.		2 Gallon Preserve Jars.		1 Gallon Preserve Jars.		1 Gallon Fruit Jars.		½ Gallon Fruit Jars.		1 Gallon Flower Pots.		½ Gallon Flower Pots.		¼ Gallon Flower Pots.		Hanging Flower Baskets, large		" " " small
Pieces	6 Gallon Pots.																																																														
	5 Gallon Pots.																																																														
	4 Gallon Pots.																																																														
	3 Gallon Pots.																																																														
	2 Gallon Pots.																																																														
	1 Gallon Pots.																																																														
	½ Gallon Pots.																																																														
	6 Gallon Pot Covers.																																																														
	5 Gallon Pot Covers.																																																														
	4 Gallon Pot Covers.																																																														
	3 Gallon Pot Covers.																																																														
	2 Gallon Pot Covers.																																																														
	1 Gallon Pot Covers.																																																														
	6 Gall. Churns with.....covers																																																														
Pieces.	5 Gall. Churns with.....covers																																																														
	4 Gall. Churns with.....covers																																																														
	3 Gall. Churns with.....covers																																																														
	1 Gallon Milk Pans.																																																														
	½ Gallon Milk Pans.																																																														
	2 Gallon Jugs.																																																														
	1 Gallon Jugs.																																																														
	½ Gallon Jugs.																																																														
	2 Gallon Preserve Jars.																																																														
	1 Gallon Preserve Jars.																																																														
	1 Gallon Fruit Jars.																																																														
	½ Gallon Fruit Jars.																																																														
	1 Gallon Flower Pots.																																																														
	½ Gallon Flower Pots.																																																														
	¼ Gallon Flower Pots.																																																														
	Hanging Flower Baskets, large																																																														
	" " " small																																																														

Figure 12. Inside pages of Moingona Pottery Works order form (Anderson 1974)

other two forms.

Chandler and Deering also had calling cards, which were printed on a cardboard-like paper. An example is shown in Figure 13. These cards were probably passed out by the travelling agent to prospective customers. The card extols the quality of the Moingona Pottery Works ware and guarantees that it will hold kerosene, brine, hot lard and oil.

An example of a Flint Stone Pottery order form is shown in Figure 14. This form was a single sheet of paper which listed the types and sizes of ware available. This form also had the numbers 187 printed on it indicating it was used during the 1870's. The types and sizes of ware manufactured at the Flint Stone Pottery were very similar to those manufactured by the Moingona Pottery Works. The one to six gallon jars of the Flint Stone Pottery may be the same as the one to six gallon pots of the Moingona Pottery Works. The differences between the listed wares of the two Moingona potteries shows that the Moingona Pottery Works made $\frac{1}{2}$ gallon milk pans, and 2 gallon large hanging baskets. The Flint Stone Pottery made $\frac{1}{2}$ gallon preserve jars, $\frac{1}{4}$ gallon fruit jars, 1 gallon chambers, and 5 gallon vases.

Prices of ware The price of ware was usually determined according to how many gallons a vessel held, with lids counting as one gallon. The order forms of the Moingona potteries did not list the prices of ware, however, there are

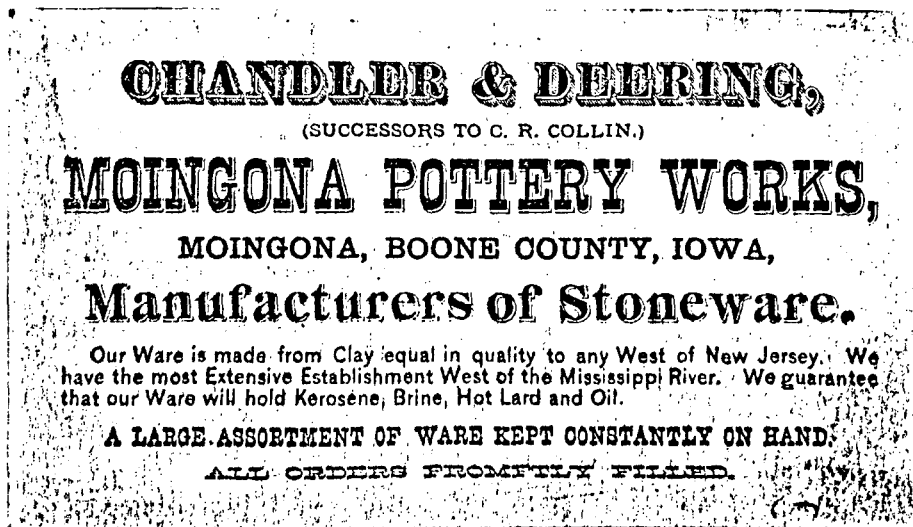

Figure 13. Moingona Pottery Works calling card
 (Anderson 1974)

several sources that provide information on prices. The first source is taken from the shipping book of Chandler & Deering for the period 1875 to 1877. The following prices of flower pots and hanging baskets were listed in this book: 1 gallon flower pots \$1.50 per dozen, $\frac{1}{2}$ gallon flower pots \$1.25 per dozen, $\frac{1}{4}$ gallon flower pots \$1.00 per dozen, 1 gallon hanging baskets \$1.80 per dozen, and 2 gallon hanging baskets \$2.40 per dozen (Anderson 1974).

The second source of price information is provided by the 1882 circular that was sent out by the Iowa potteries to the merchants that were buying their ware (Figure 61). This circular set the prices of butter pots, pickle jars, churns, and milk pans at seven and one half cents per gallon and jugs were to be sold at nine cents per gallon (Anderson 1974).

Wages of potters The wages paid to potters were determined upon either a daily or monthly rate or a "piece work" basis according to the number of gallons of ware a potter made in a day. A generalized discussion of wages is given by Harold F. Guillard:

Most labor in America during the first half of the nineteenth century was agricultural and wages for both skilled and unskilled workers were somewhat regulated by this. Journeymen potters' wages were still often paid in trade goods, and accounts were figured in English sterling until well in the century. The cash wage for potters was about a dollar a day with room and board, or fifteen dollars if hired by the month. In some areas potters' wages were figured on a "piece work" basis by the gallon.

A gallon pot worth one or two cents each and the average daily wage was about the same as a daily wage (Guilland 1971:52).

The above account of wages is similar to wages received by potters in Boone County as can be seen from an article in the December 11, 1869, issue of the Montana Standard in which the potteries in Boone County were discussed:

A skillful turner will make about 200 gallons of ordinary ware of average size each day, for which he receives about 2½ cts. per gallon (Montana Standard: December 11, 1869).

Because wages were often on the basis of "piece work," the speed in which a potter could complete a vessel directly determined how much he could make. An account of the speed in which potters could work was found in a June 6, 1874, newspaper article from The Ogden Reporter. This account was in reference to the Moingona Pottery Works.

. . . we timed one workman making gallon jugs and he turned out five in eight minutes, and another working on flower baskets with scalloped edges, made four in five minutes (The Ogden Reporter: June 6, 1874).

The October 3, 1872, Boone County Democrat also discusses the wages of workers employed by the Moingona Pottery Works and seems to include those workmen who were not potters.

They employ from 18 to 25 hands, who earn from \$20 to \$80 per month (Boone County Democrat: October 3, 1872).

Although no references were found indicating the wages paid to workers employed by the Flint Stone Pottery it is

assumed they were commensurable with the wages of the Moingona Pottery Works.

CHAPTER FIVE: ARCHAEOLOGICAL INVESTIGATIONS

Location and Description of the Sites
and Surroundings

The archaeological sites 13BN120 (Moingona Pottery Works) and 13BN132 (Flint Stone Pottery) are located in the Des Moines River Valley within the unincorporated town of Moingona, Iowa. These two sites were designated in 1969 by the Iowa State University Archaeological Laboratory and are included in the archaeological salvage survey and reservoir impact study conducted by the United States Army Corps of Engineers and Iowa State University (Gradwohl and Osborn 1973). The locations of these sites in relation to Saylorville Reservoir are shown in Figure 15.

13BN120

Site 13BN120 is located at an elevation of 870-905 feet, slightly to the north of the town of Moingona, Iowa. The approximate location is shown in Figure 3. The site was first brought to the attention of the Iowa State archaeological crew in the summer of 1969 by Mrs. Mary Miller of Boone, Iowa. A preliminary surface collection was taken on July 7, 1969. Additional materials, here analyzed, were obtained up to 1974. The material collected indicated the site was an historic Euro-American kiln dump area. Site 13BN120 is located east of the old Chicago and North~~W~~estern Railroad

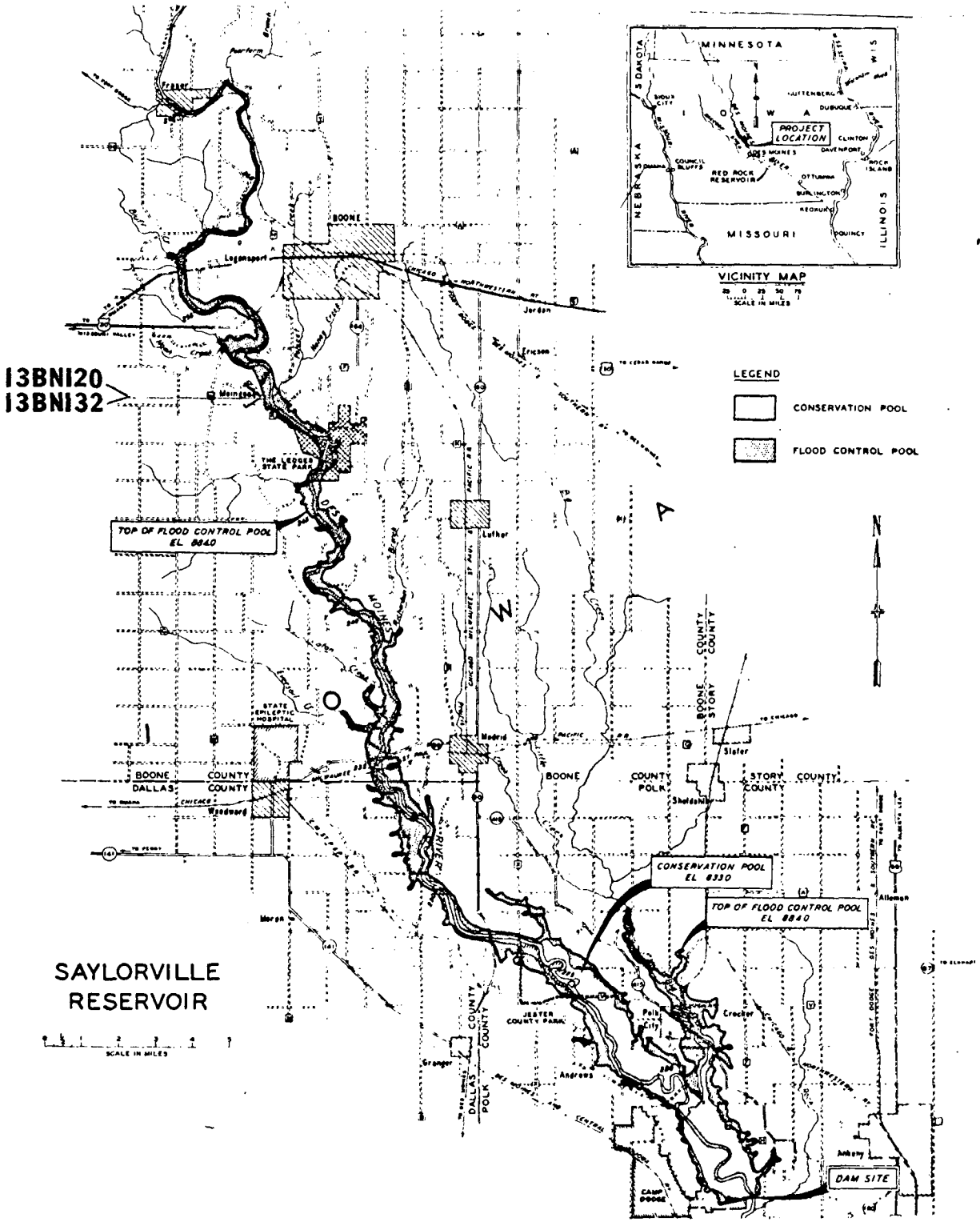

Figure 15. Map of Saylorville Reservoir (U.S. Army Corps of Engineers 1964) showing general location of 13BN120 and 13BN132 at Moingona

tracks on the west bank of the Des Moines River. A narrow strip of timber and thick underbrush follows the course of the Des Moines and it is within this strip that 13BN120 is located. To the west of this timber is an open field which had been farmed before the United States Army Corps of Engineers acquired ownership of the land (Figure 16).

A large concentration of ceramic material was found scattered along the slope of the river bank and there were also indications of clay pits along the slope. The Montana Standard of November 27, 1869, mentioned that the Moingona Pottery Works obtained their clay from outcrops along the bluff on which the buildings stood. The slope may have also served as a waster dump in which broken ware and pieces of clay used in stacking the ware in the kiln were discarded. Ceramic material has also been washed out of the banks through rainfall and by action of the river. Much of this washed out material has been carried by the river and deposited further downstream.

13BN132

Site 13BN132 is located at an elevation of 895-900 feet, within the town of Moingona, as shown in Figure 3. This site was also shown to the Iowa State archaeological crew by Mrs. Mary Miller. Initial surface collections were made on June 26 and 27, 1969. Subsequent collections, here analyzed, up to 1974. From the material recovered it was determined the

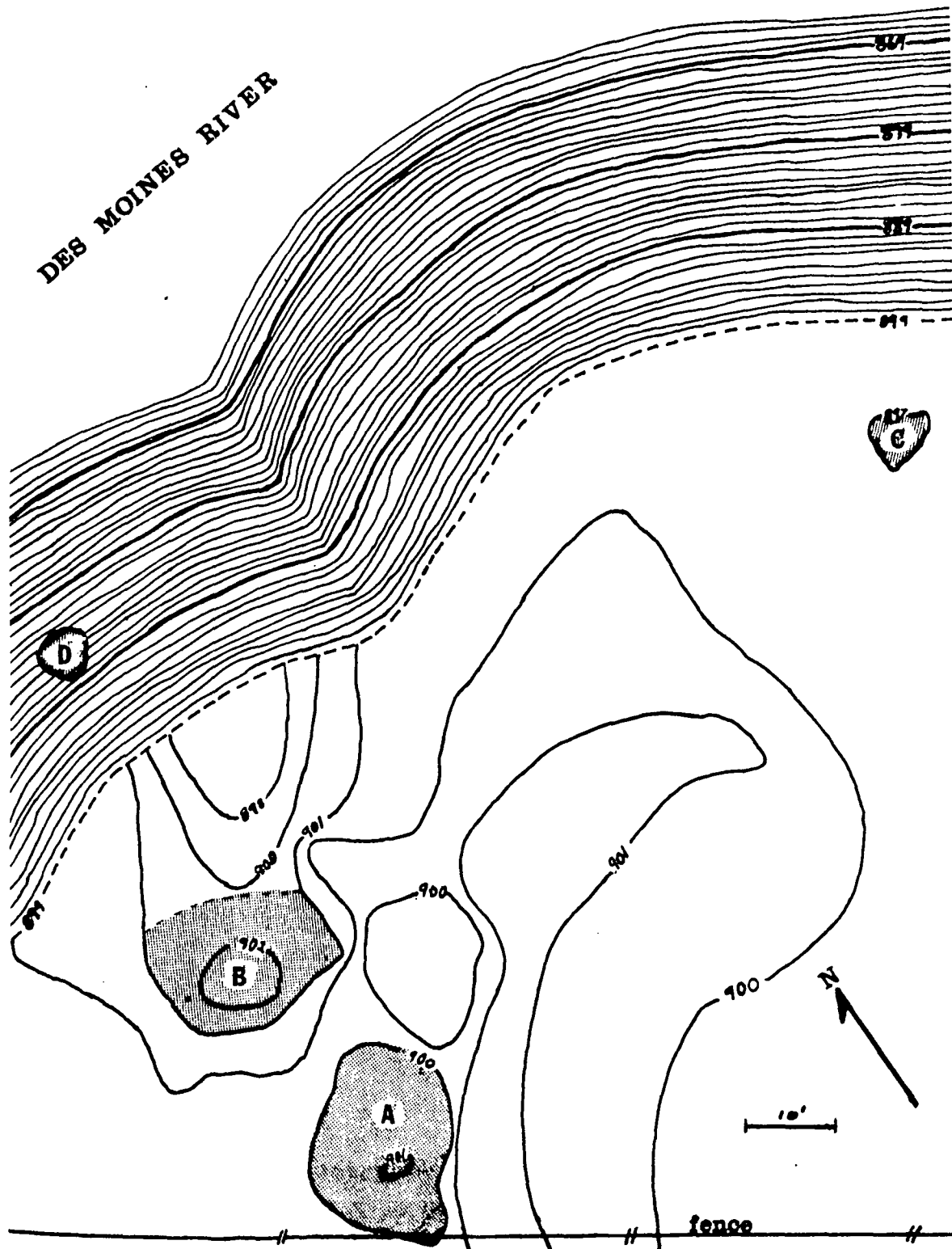

Figure 16. Topographic map of the Moingona Pottery Works locality showing location of A,B) kiln mounds; C) well; D) clay pit

site was an historic Euro-American pottery kiln dump area. This site is located south of 13BN120 and west of the old Chicago & Northwestern Railroad tracks on a low lying, flat piece of land. The land is covered by timber and thick underbrush and is surrounded by a barb wire fence. A small garden plot lies to the west of this area and a scattering of ceramic material has been uncovered in the process of plowing the land prior to planting a crop. The land on which the site is located is presently owned by Donald M. and Grace J. Wilhite.

Structural Evidence

Surface collections from both sites yielded structural evidence that was related to the pottery kilns. Fire brick and red brick were found with heavy accumulations of salt glaze indicating these bricks were once part of a kiln.

13BN120

At 13BN120 (Moingona Pottery Works) there are two three foot high mounds approximately eight feet apart, and situated in an north-south direction from the Des Moines River (Figure 16). There is a large accumulation of glazed brick scattered on these mounds. These may represent the remains of the Moingona Pottery Works kilns shown in Plate 1. A hole approximately three feet in diameter and two feet deep lies about 15-20 feet northeast of the mounds. Glazed and unglazed

bricks surround the walls of the hole and an iron pipe is located in the center of the hole, which may represent a well (Figure 16C). There was also a hole in the slope of the bank that may have been an area where clay was taken from (Figure 10).

13BN132

At site 13BN132 (Flint Stone Pottery) there is a large section of concrete with three stair steps and also a large scattering of unglazed brick. The stair steps and brick may represent the remains of the pottery which was a three story brick building (Boone County Advocate: December 8, 1870).

General Characteristics of the Ceramic Wares

Over 2899 artifacts collected from the surface 13BN120 and over 3659 artifacts from 13BN132 were related to the production of ceramic ware. These artifacts included potsherds and ceramic industrial waste products in addition to material related to the more general pioneer settlement of Moingona.

The wares from both sites were heavy utilitarian wares with generally thick ($\frac{1}{4}$ " to $\frac{1}{2}$ ") walls. There was a regularity in form of much of the pottery suggesting molds and templates were used in the manufacturing process. The ware characteristically had either a salt or a brown slip glaze or some combination of the two.

The ware was placed into functional vessel categories based upon historically known categories such as crocks, jugs, milk pans, churns, etc. An attempt was made to then correlate the material in these functional categories with the ware listed on the order forms from the two potteries. The criteria used to separate the archaeological residue into the various functional categories was based upon the following measurements and observations:

internal and external rim diameter	rim type
internal and external neck diameter	rim height
internal and external glaze	rim thickness
internal and external color	wall thickness
decoration	base thickness
	base diameter

This information provided the basic data for the analysis of the ceramic material from sites 13BN120 and 13BN132.

Rim sherds were studied in greater detail than any other sherds because they provide the most information about particular vessel types. Rims, as well as handles, also indicate an individual potter's personal touch, as Ivor Noel Hume (1969:166) has commented:

It has been said that a potter is known by his rims and handles, for having learned to make them he would in all probability continue to employ the same technique throughout his working life. The potter who pinched the ends of his handles or who undercut his rolled rim would do so regardless of whether he was producing a porringer or a chamber pot. The potter who rolled his rims would never fold them; one who ridged them on the top would never cut them square. These were simply idiosyncrasies and, like fingerprints, they did not change.

Rim and handle types may be important for identifying the ware of a particular potter or pottery. Another more direct method of distinguishing potteries is by the decorations on their ware. Cobalt blue slip underneath a salt glaze was the most common form of decoration used by both potteries. Sherds were found from both sites on which the name of the pottery had been stenciled in cobalt blue. This type of information provides a direct link between the archaeological residue and the archival data for determining that site 13BN120 is the Moingona Pottery Works and site 13BN132 is the Flint Stone Pottery. This linkage will be discussed in greater detail in the section on crocks.

Description of Vessel Types

This section will describe and illustrate the various wares produced at sites 13BN120 and 13BN132. There were no complete vessels and only a few partially reconstructed vessels. The material collected from site 13BN120 yielded 676 rim sherds, 536 body sherds, and 461 base sherds. Site 13BN132 yielded 1521 rim sherds, 586 body sherds, and 718 base sherds. As was previously mentioned these wares will be placed into categories according to function, using historical documentation. There are a few wares whose functions, because of a lack of historical documentation and small sample, cannot be demonstrated. Therefore, only possible functions have been

proposed.

Vessel category: milk pans

Milk pans have been referred to as milk skimming bowls (Reynolds 1970:136) and were used for separating cream from milk. Milk pans are shallow, slant-sided vessels with thick rims. Milk pans were one of the larger categories of material collected from both sites. The general uniformity in appearance and absence of noticeable finger marks on the interior suggest they may have been manufactured by means of a jolly, the operation of which was discussed on page 39. Milk pans were stacked one inside the other in the kiln. By stacking the pans in this manner the Albany slipped surfaces were protected from the salt glaze and this also left an unglazed surface directly below the rim. Several rims were found stuck together in this manner. To prevent this from happening the rims were wetted and dipped in sand. One rim from 13BN120 had a coil of clay attached to the interior surface, and may represent an experimental method of stacking pans together.

13BN120 The milk pans from site 13BN120 (Moingona Pottery Works) indicate only one type of mold having been used. Milk pans from this site have rounded base/wall junctures and a small ridge on the base, near the edge (Figure 17A). There were 556 milk pan sherds from 13BN120, this included 250 rim sherds, 214 base sherds, 92 body sherds, and 1 compound rim

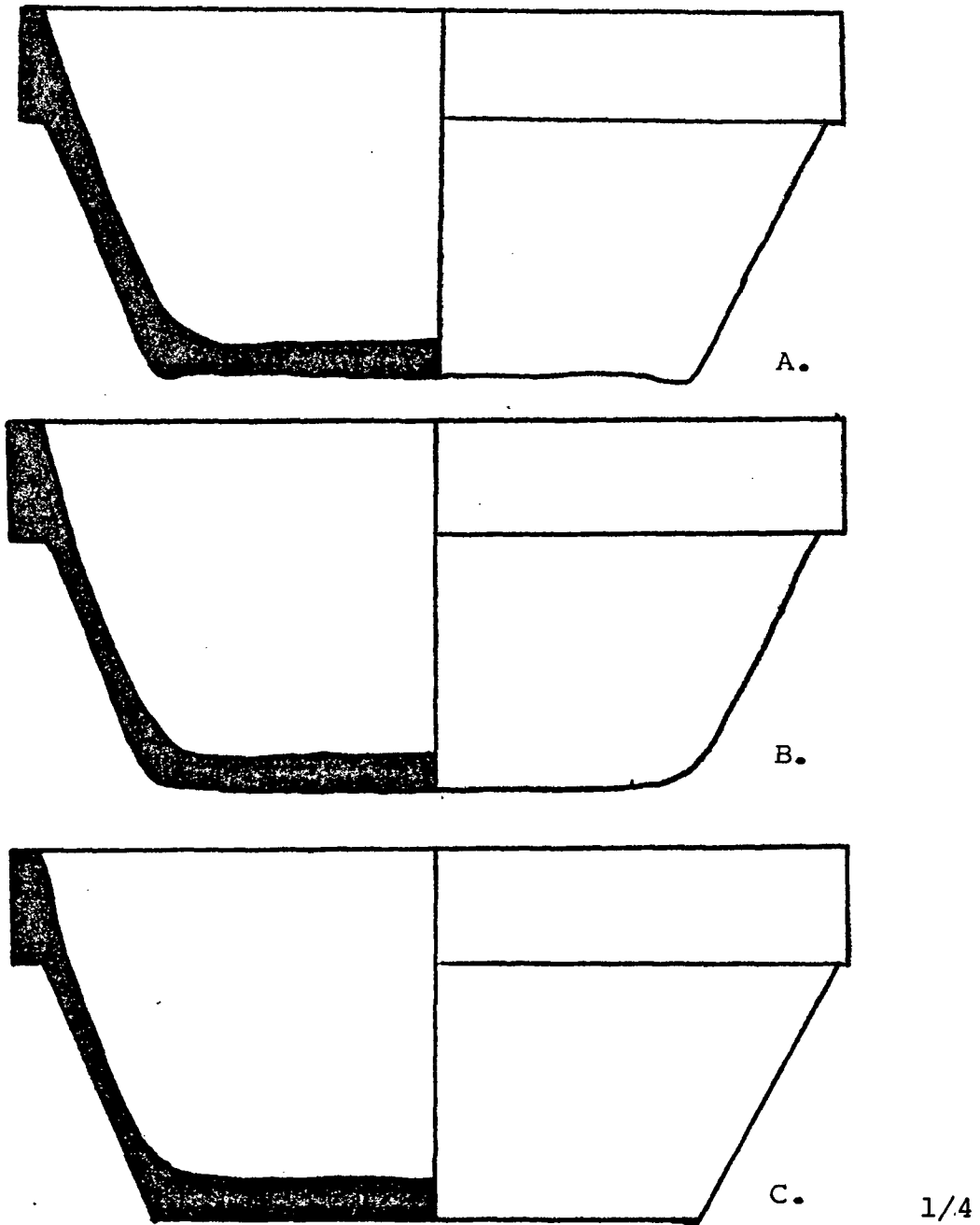

Figure 17. Milk pan forms: A) type from 13BN120; B) Category A from 13BN132; C) Category B from 13BN132

sherd. The following list gives the range of measurements, in millimeters, for milk pans from 13BN120:

Number of round base milk pans	214
Diameter of orifice	260-280
Rim thickness at base of wedge	10-13
Rim height	37-47
Total height of vessel	110-119
Base thickness	4-8
Wall thickness	6-9

Although the order forms from the Moingona Pottery Works show one gallon and half gallon milk pans being sold, the measurements taken do not indicate two different sizes. This may be partly explained by the fact that there are no reconstructed vessels from which to accurately measure capacity. There was also one milk pan from 13BN120 which was Albany slipped on both the exterior and interior surface. One milk pan rim was stamped with the name of the pottery (Figure 18), which is very unusual and is the only example found from either site.

13BN132 There is evidence two different molds were used at site 13BN132 (Flint Stone Pottery). The first type, designated Category A, produced a slightly rounded base/wall juncture, the second type, designated Category B, produced more sharply angled base/wall junctures (Figure 17B&C). There were 1392 milk pan sherds from 13BN132, this included 1075 rim sherds, 38 square base sherds, 134 round base sherds, 28 unidentified base sherds, 113 body sherds, and 6 compound rim sherds. The following list gives the range of measurements,

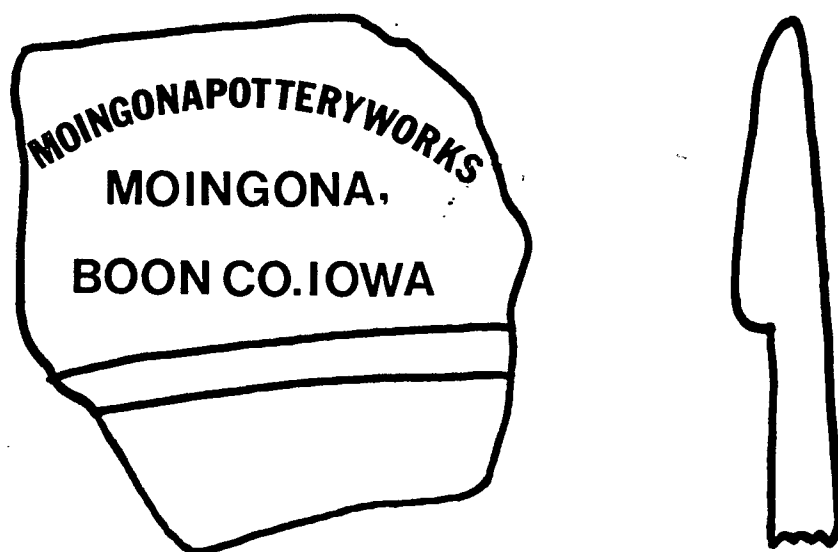

1X

Figure 18. Stamped milk pan rim sherd from 13BN120

in millimeters, for milk pans from 13BN132:

Category A milk pans (total number 134)
 Diameter of orifice 270-300
 Rim thickness at base of wedge 12-15
 Total height of vessel 110-114
 Base thickness 8-11
 Wall thickness 8-11

Category B milk pans (total number 38)
 Diameter of orifice 280-285
 Rim thickness at base of wedge 13-15
 Rim height 43-45
 Total height of vessel 110-112
 Base thickness 5-10
 Wall thickness 6-11

There were no molds found at either site, possibly because they were made of plaster of Paris which might have deteriorated leaving no residue. Portions of plaster of Paris molds are known, however, from the waster dump associated with the Ft. Dodge Stoneware Company (13WB150) in Webster County (Gradwohl 1973). It is also possible that molds were bisque ware and were sold along with the jolly and jigger. Two milk pan rims were found with cobalt blue lines, which was probably done either accidentally or experimentally. They are the only examples found from either site.

Vessel category: crocks or pots

Crocks or pots ranged in size from one gallon to six gallons and larger. The larger sizes sometimes referred to as tubs, were often used for shipping butter to market (Guilland 1971:134). Crocks were used to preserve cooked meat and fish food and were sealed with clarified butter or lard (Guilland

1971:106), or were used as storage containers for such things as dye, soap, lard, pickles, sugar, flour, and eggs (Guilland 1971:125). Often one or more incised lines or striations were made below the rim just before the pot was removed from the wheel. A striation is a groove or removal of clay which marked the height at which handles were to be applied and also acted as a form of decoration (Guilland 1971:108). Two crocks from 13BN120 and one crock from 13BN132 have incised wavy lines below the rims as a type of decoration (Figure 19).

There appear to be two main divisions in the crock category, large diameter and small diameter crocks. There were 997 large crock sherds and 121 small crock sherds from site 13BN120. From 13BN132 there were 1381 large crock sherds and 207 small crock sherds. The frequencies and measurement of large and small crocks for 13BN120 and 13BN132 are shown in Figure 20. Based on observations and measurements, the large crocks generally have salt glazed exteriors and interiors or Albany slipped interiors, two "U" shaped handles, one or more striations and reserve rims (Figure 21). A reserve rim is made by bringing a "reserve" ridge of clay up the side of the vessel while it is spinning and finishing the ridge in a variety of ways at the top of the vessel. The small diameter crocks generally have Albany slipped exteriors and interiors, do not have handles or striations and have both reserve and folded rims. A folded rim is one that has been

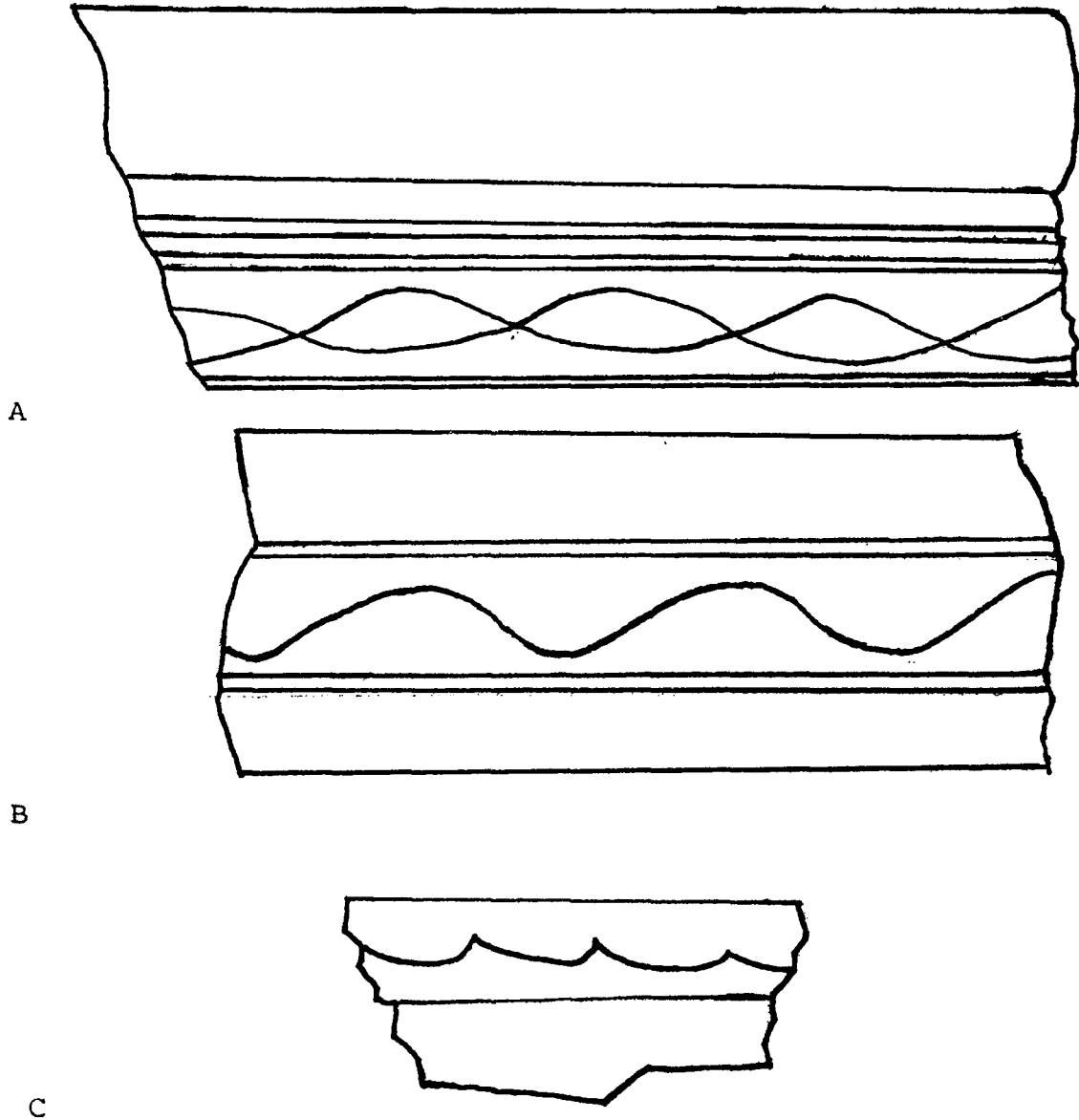

1X

Figure 19. Decorated crock rims: A,B) from 13BN120; C) from 13BN132

FREQUENCIES

	13BN120	13BN132
Large Diameter Crocks		
Reserve Rims	231	391
Reserve Rims with Cobalt Blue	61	58
Body Sherds	284	274
Body Sherds with Cobalt Blue	198	217
Base Sherds	214	413
Bases with Cobalt Blue	9	27
Straight Rims with Cobalt Blue	2	
Straight Rims	1	1
Small Diameter Crocks		
Reserve Rims	22	48
Body Sherds	18	42
Base Sherds	77	114
Folded Rims	2	5
Straight Rims	3	3

MEASUREMENTS

	13BN132	13BN120
Large Diameter Crocks		
Interior Rim Diameter	180-300 mm	180-434 mm
Exterior Rim Diameter	200-320 mm	200-459 mm
Rim Thickness	17- 23 mm	16- 25 mm
Rim Height	20- 40 mm	25- 50 mm
Base Diameter	180-300 mm	170-300 mm
Base Thickness	6- 13 mm	5- 11 mm
Wall Thickness	7- 13 mm	9- 11 mm
Small Diameter Crocks		
Interior Rim Diameter	130-190 mm	120-170 mm
Exterior Rim Diameter	140	130-200 mm
Rim Thickness	7- 18 mm	14- 19 mm
Rim Height	10- 24	15- 22 mm
Base Diameter	105-210 mm	160-200 mm
Base Thickness	5- 14 mm	5- 11 mm
Wall Thickness	4- 12 mm	5- 10 mm

Figure 20. Table of frequencies and measurements of large and small diameter crocks from 13BN120 and 13BN132

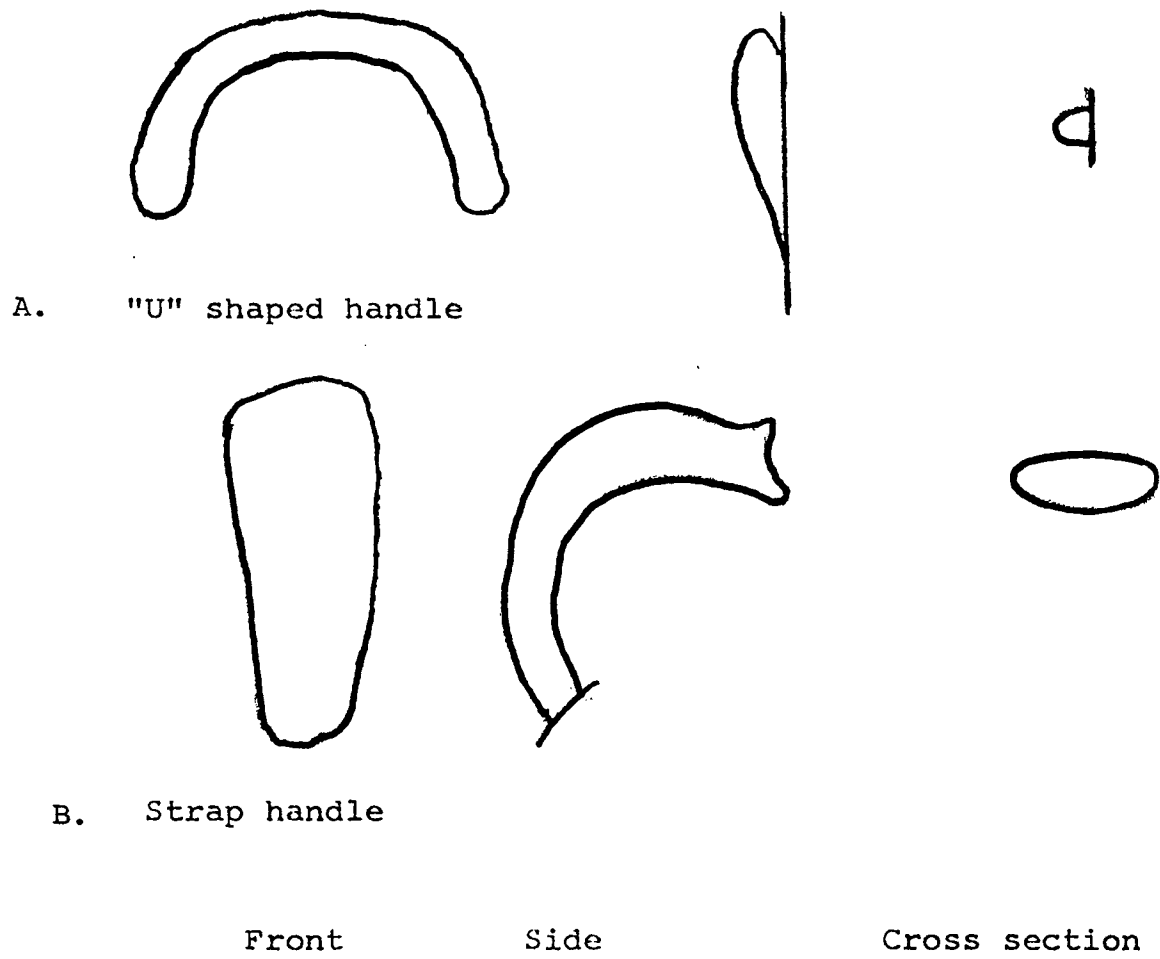

1/2

Figure 21. Vessel handle forms: A) found on crocks and churns; B) found on jugs

folded away from the wall of the vessel. Figures 22 and 23 show the range of variations of crock rims from both sites. A distinctive feature of some crocks and also churns is the use of cobalt blue decoration. Cobalt blue was used to mark the name of the pottery, the number of gallons a vessel held, and for designs such as flowers and butterflies. The frequencies of cobalt blue decorated sherds from 13BN120 and 13BN132 are shown in Figure 24.

13BN120 (Moingona Pottery Works) cobalt blue and stamped decorations

There were 270 cobalt blue marked crock sherds and one stamped crock sherd from 13BN120. The one crock rim/body sherd was marked with the same stamp that was used on the milk pan rim shown in Figure 18. Lettering with the name of the pottery appeared on 47 sherds. This lettering provides the linkage between the archaeological residue and the archival data because we can then know that site 13BN120 is the Moingona Pottery Works and that site 13BN132 is the Flint Stone Pottery. At least four different stencils were used for marking the name of the pottery on ware from 13BN120. The different types are shown in Figures 25 and 26 with the frequencies of each type given in Figure 24. Two sherds were marked with the name Deering, and are probably from the period 1875 to 1877 when Chandler and Deering leased the pottery (Figure 27). Mrs.

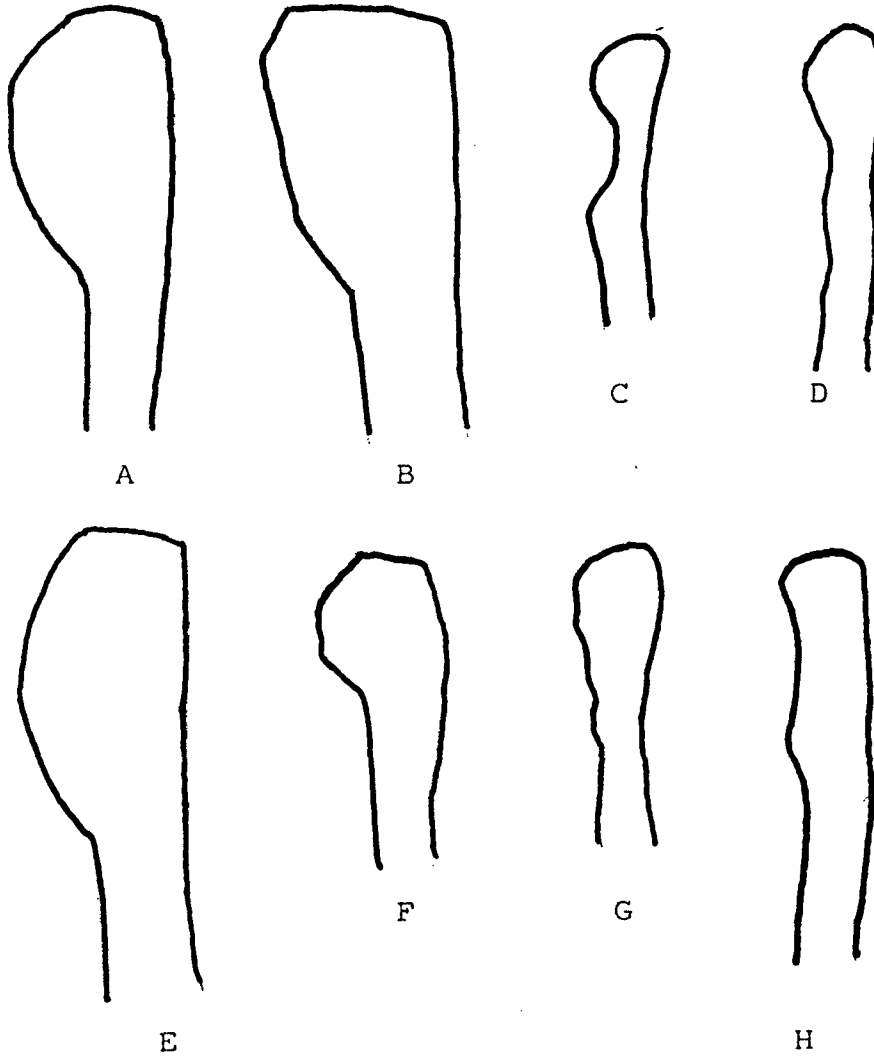

1X

Figure 22. Variations in crock rim forms: A,B) large reserve rims from 13BN132; C,D) small reserve rims from 13BN132; E) large reserve rim from 13BN120; F,G,H) small reserve rims from 13BN120

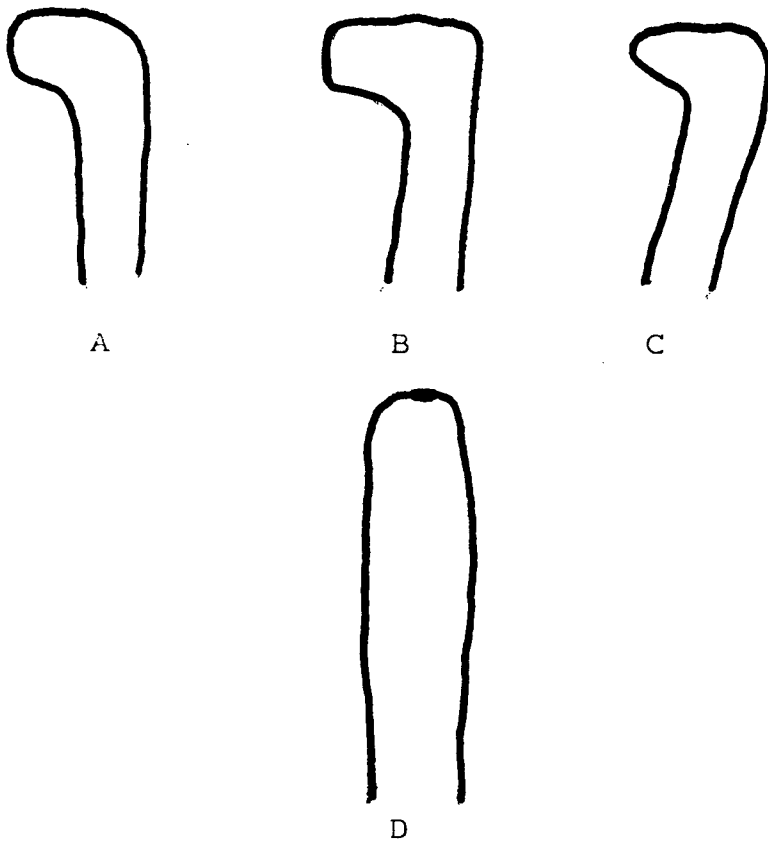

1X

Figure 23. Variations in crock rim forms: A,B) folded rims from 13BN132; C) folded rim form 13BN120; D) straight rim from 13BN120

Large Crocks with Cobalt Blue	13BN120	13BN132
Lettering		
Type A	6	15
Type B	11	7
Type C	15	1
Type D	3	
Type E	2	
Unidentifiable	<u>10</u>	<u>5</u>
	47	28
Stenciled Numerals		
Number 2	11	
Number 3	6	1
Number 4	7	1
Number 5	9	
Number 6	<u>3</u>	<u>1</u>
	36	3
Script Numerals		
Number 2	3	16
Number 3	5	19
Number 4		6
Number 5	4	6
Number 6		<u>3</u>
	<u>12</u>	50
Circles of Stars	16	6
Circles of Dots	<u>42</u>	<u>6</u>
	58	
Leaf Designs		
Brushed	8	13
Slip trailed	<u>6</u>	<u>2</u>
	14	15
Flower Designs		
Brushed	2	
Slip Trailed	<u>3</u>	
	5	
Cyclone Designs		
Type A	11	10
Type B	<u>9</u>	<u>11</u>
	20	21
Butterfly Designs		
Type A		23
Type B		<u>18</u>
		41
Circle Designs		40
Miscellaneous Designs	20	5
Unidentifiable Designs	58	94

Figure 24. Table of frequencies of cobalt blue decorated sherds from 13BN120 and 13BN132

MOINGONA

POTTERY WORKS
MOINGONA, IOWA



A

MOINGONA

POTTERY WORKS
MOINGONA, IOWA

1X



B



Figure 25. Cobalt blue lettering from Moingona Pottery Works (13BN120): A) Type A; B) Type B

**FROM
MOINGONA POTTERY WORKS**



MOINGONA . MOING

106

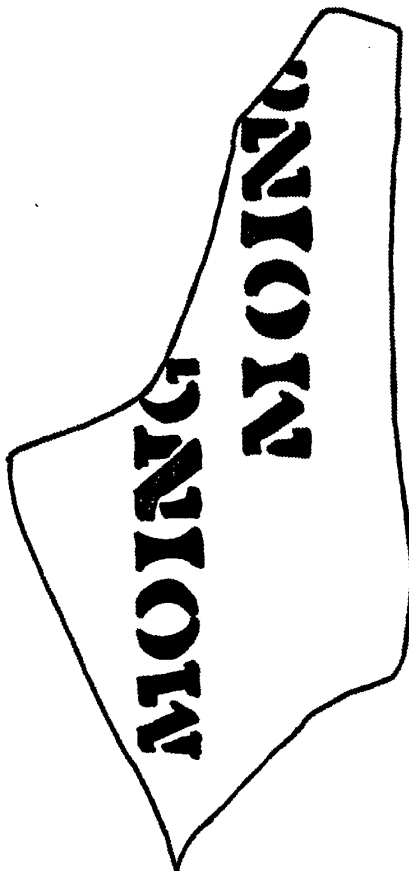

1x

Figure 26. Cobalt blue lettering from Moingona Pottery Works (13BN120): A) Type C;
B) Type D



1X

Figure 27. Cobalt blue lettering from Moingona Pottery Works (13BN120) Type E

Eloise Anderson also has a sherd from this site which has "andler & De" stenciled on it. Another sherd had "E.A." stenciled on it, but it is not known what the initials stand for.

Numerals were used to designate the number of gallons a vessel held. A total of 48 sherds from 13BN120 had numerals on them. Of the 48 sherds 36 were stenciled and 12 were in script (i.e. done by hand with a slip trailer). The stenciled numerals were often enclosed by one or more circles of dots or stars which were probably part of the same stencil. There were 58 sherds that had part of these circles but the numerals they inclosed could not be determined. A stencil found in Mrs. Anderson's collection of G. W. Chandler's material was made from a piece of tin in which the numerals 0 through 9 had been cut out (Figure 58). A similar type of stencil was probably used for marking the name of the pottery.

Some 117 sherds from 13BN120 had some type of design. Designs were either slip trailed or brushed onto the ware and at least four designs were distinguished for 13BN120. These included leaves, flowers, cyclones, and miscellaneous patterns. Additional designs are probably present but because sherds were too small to distinguish an overall form these sherds were placed into an unidentifiable category of design. The names of designs are not meant to represent original classifications of the potters but are an attempt to classify designs according

to appearance. Flowers and leaves were common designs used to decorate salt-glazed ware during the nineteenth century, throughout the eastern and midwestern United States (Guilland 1971). Examples of the various slip trailed and brushed leaf and flower designs are shown in Figures 28 to 31.

The cyclone design is derived from the formal similarity to the weather phenomenon that frequently occurs in Iowa during the spring and summer months. The term was originally coined for this design as somewhat of a joke because Iowa State University is the home of the "Cyclones." However, cyclones or tornados were a threat to the early Iowa settlers and they had an appropriate form that could be represented on stoneware vessels. The shape of the cyclone design also lends itself very well to the process of slip trailing because the design can be made with one continuous motion. There were two basic types of cyclone designs used at either pottery (Figure 32). The first type has a spiralling form (Figure 33) and the second type has a zig-zag form (Figure 34).

There are also miscellaneous designs which consist of slip trailed lines and dots. No examples are illustrated from 13BN120 but a variation of this miscellaneous design is shown in Figure 37 from site 13BN132 (Flint Stone Pottery).

Frequencies of the various cobalt blue decorated sherds are given in Figure 24.

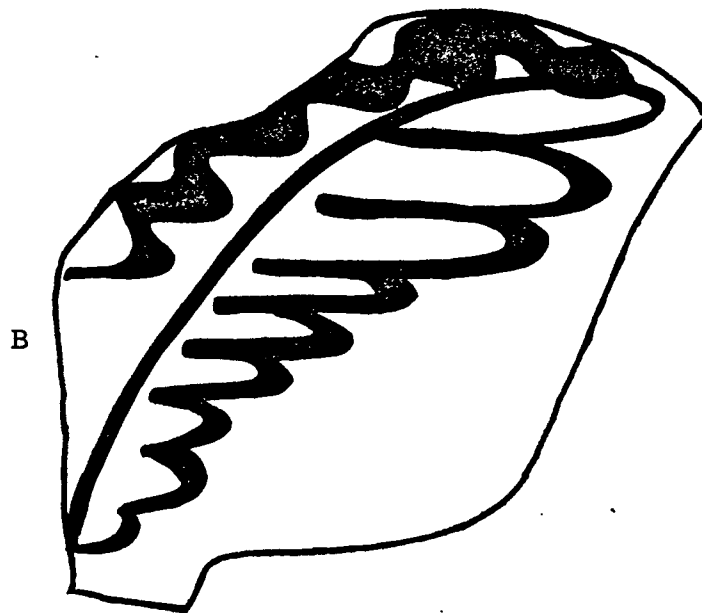
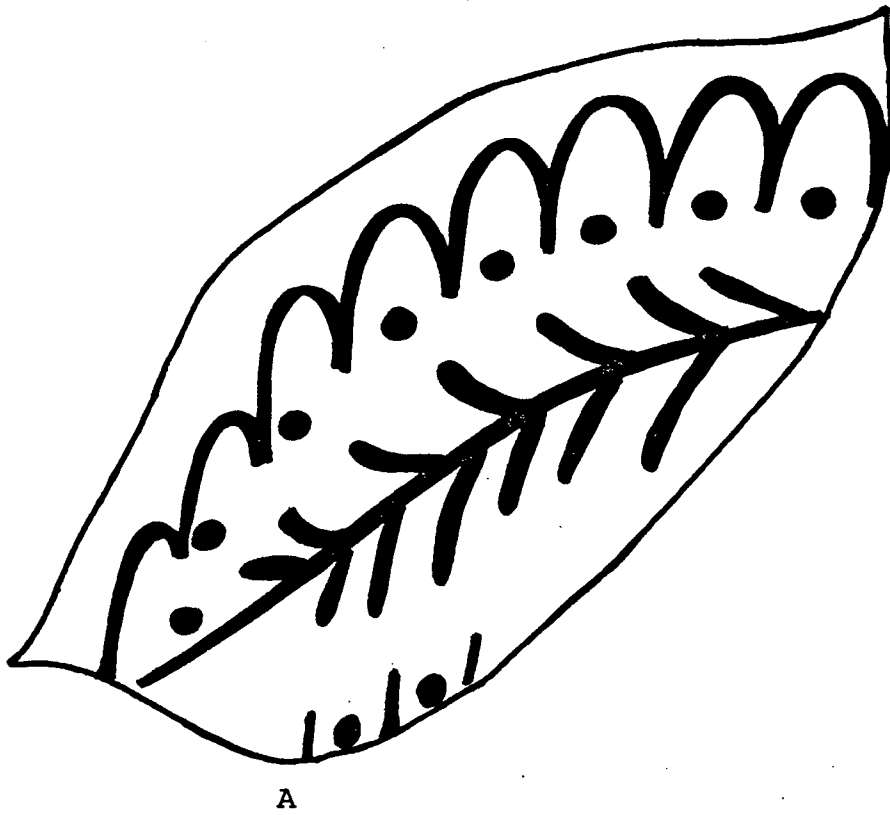

1X

Figure 28. Cobalt blue leaf designs on sherds from 13BN120

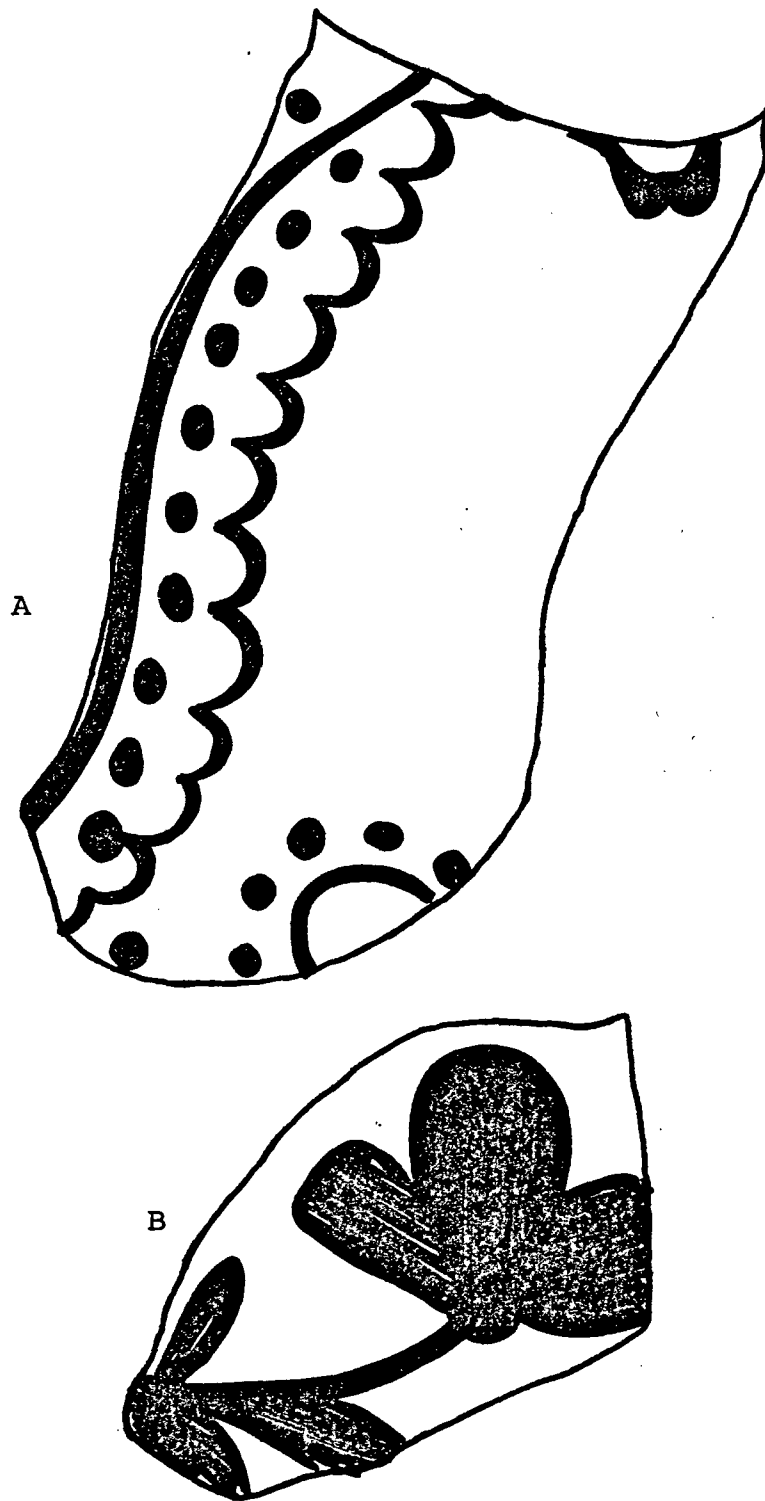

1X

Figure 29. Cobalt blue designs on sherds from 13BN120:
A) leaf design; B) flower design

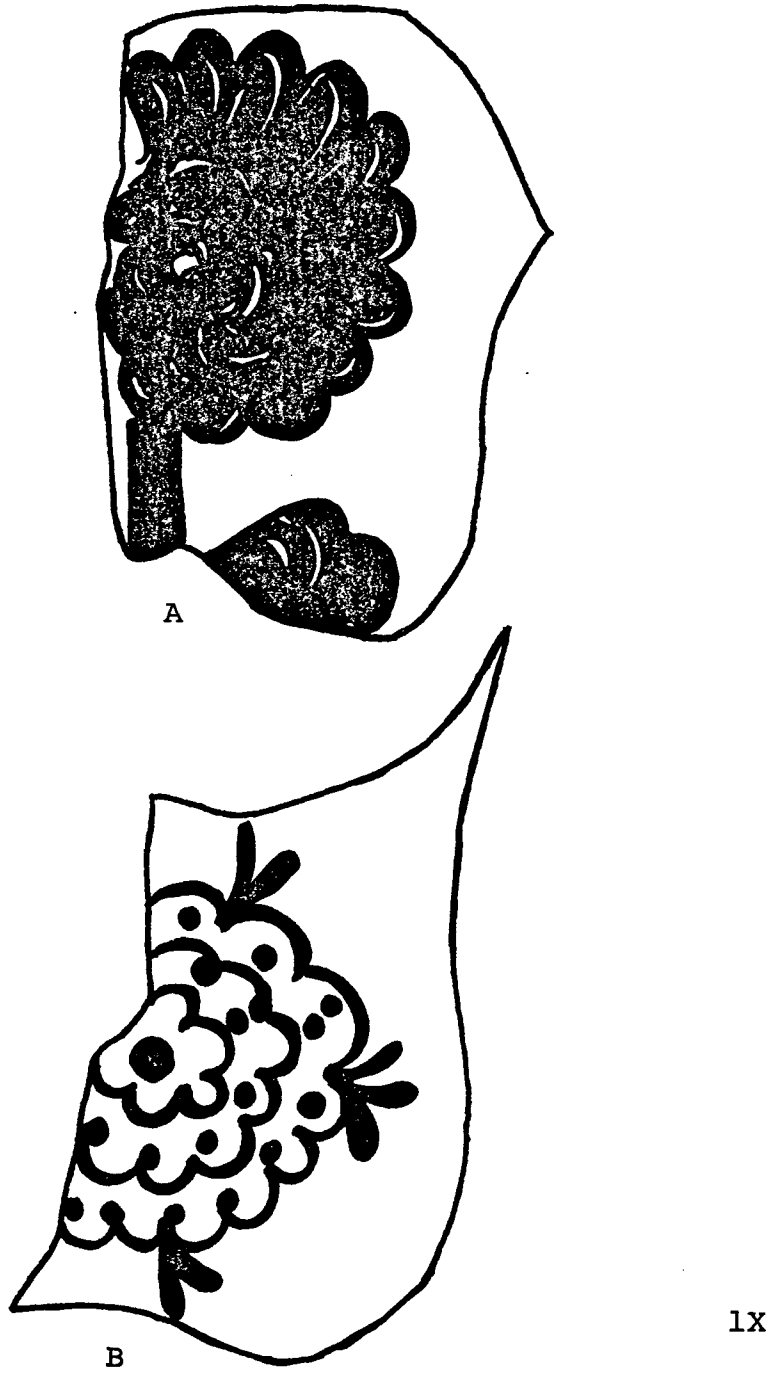
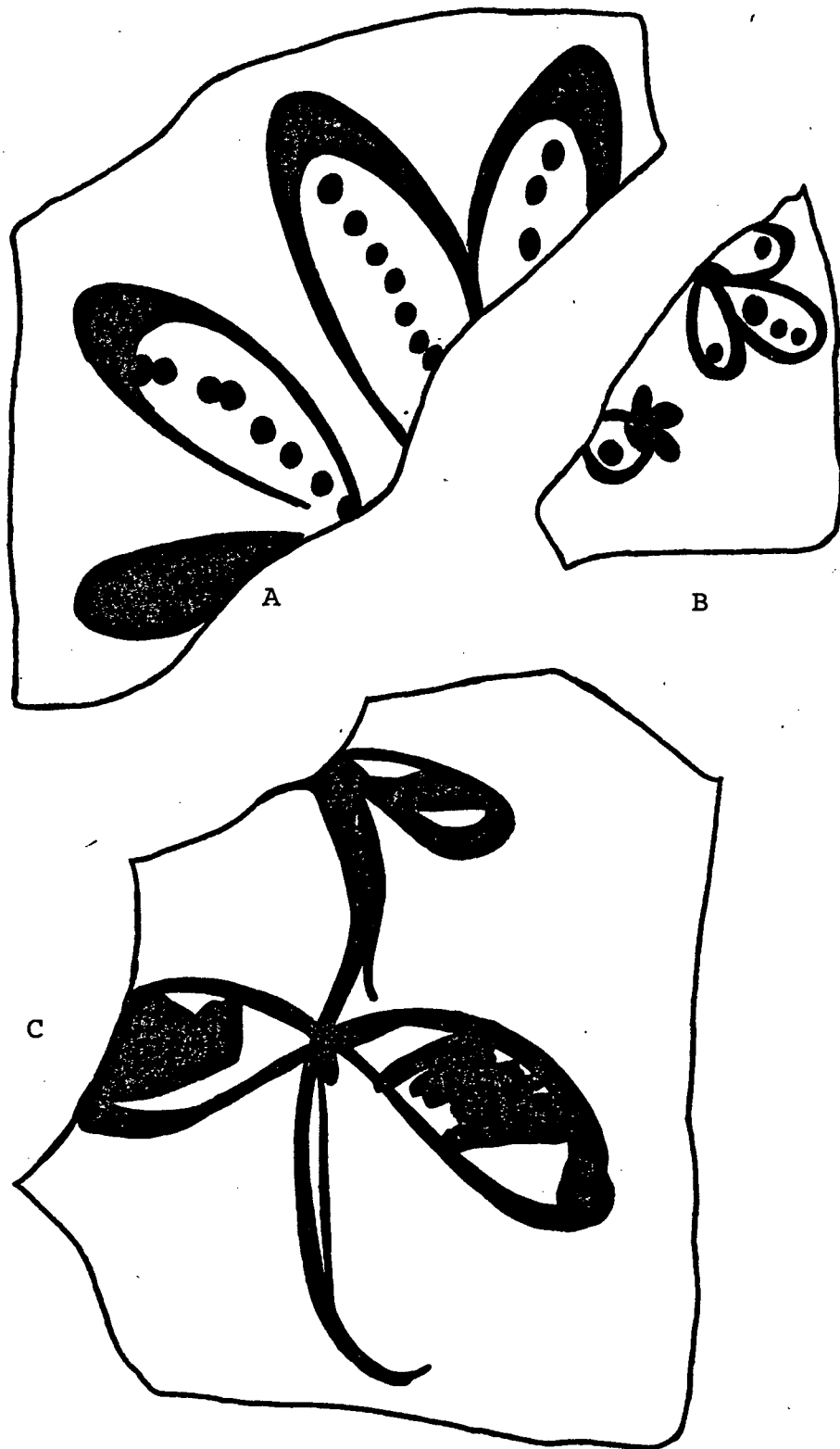

Figure 30. Cobalt blue flower designs on sherds from 13BN120



1X

Figure 3. Cobalt blue flower designs on sherds from 13BN120



A



B

1x

Figure 32. Cobalt blue cyclone designs on sherds from 13BN120:
A) Type A; B) Type B

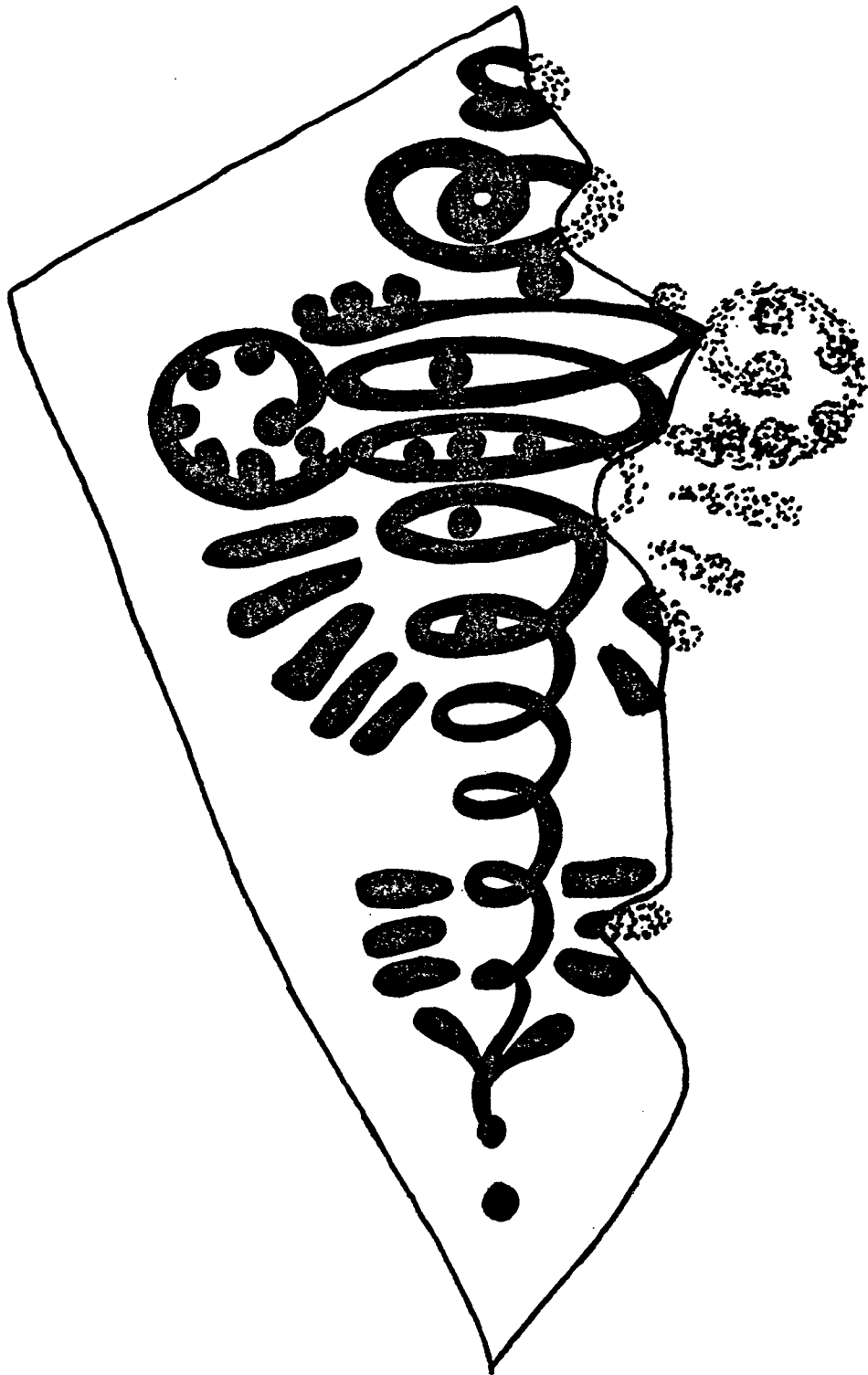

1x

Figure 33. Cobalt blue cyclone design Type A on sherd from 13BN120

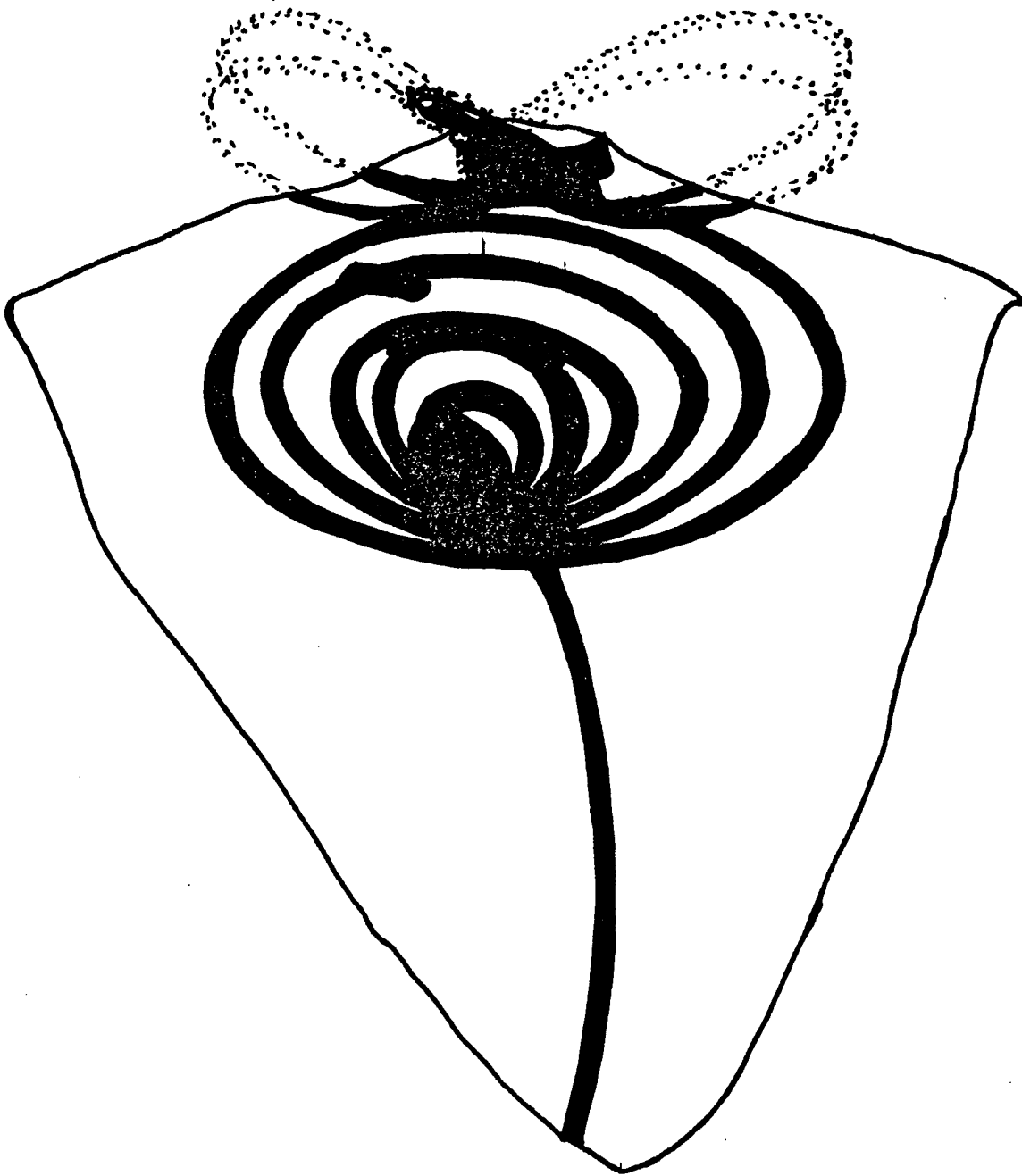

1X

Figure 34. Cobalt blue cyclone design Type B on sherd from 13BN120

13BN132 (Flint Stone Pottery) cobalt blue and stamped decorations

A total of 303 sherds from 13BN132 had some form of cobalt decoration and one sherd from this site was stamped. The stamped sherd (Figure 36B) has the last three letters of the word "Stone." A total of 28 sherds had the name of the pottery stenciled on them. There were three types of stencils with the name Flint Stone Pottery. Types A and B are shown in Figure 35 and type C shown in Figure 36A probably said "From Flint Stone Pottery, Moingona, Iowa."

Numerals appeared on 53 sherds from 13BN132, of these 3 were stenciled and 50 were in script. The stenciled numerals were much larger than the stencils found at site 13BN120. Three sherds with script numeral threes were found in combination with cyclone design type A (Figure 41). Six sherds had circles of stars.

There were 216 sherds that had some type of design from 13BN132. Five types of designs appeared within these 216 sherds; leaf, cyclone, butterfly, circle, and miscellaneous. Examples of the circle, leaf and miscellaneous designs are shown in Figure 33 and 38. There were two types of butterfly designs. Type A shown in Figure 39 is distinguished by circles within the wings. Type B shown in Figure 40 has lines along the edge of the wing and a zig-zag type of antenna. The cyclone designs shown in Figures 41 and 42 are similar to the cyclone

FLINT STONE POTTERY

MOINGONA, IOWA

FLINT STONE
POTTERY
MOINGONA, IOWA

1X

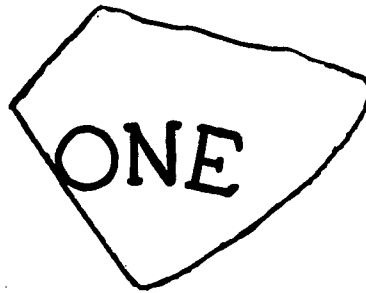
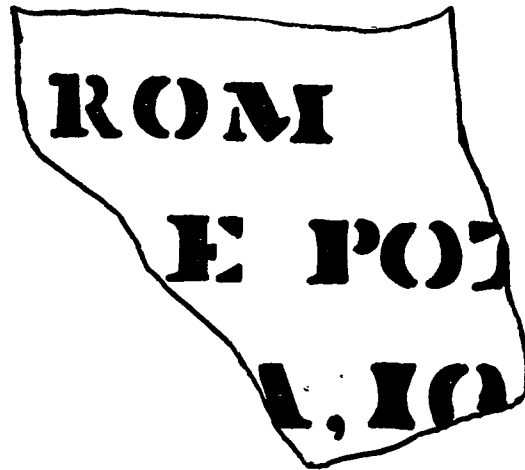
Figure 35. Cobalt blue lettering from 13BN132: A) Type A; B) Type B



1X

Figure 36. Lettering on sherds from 13BN132: A) Cobalt blue Type C; B) stamped sherd

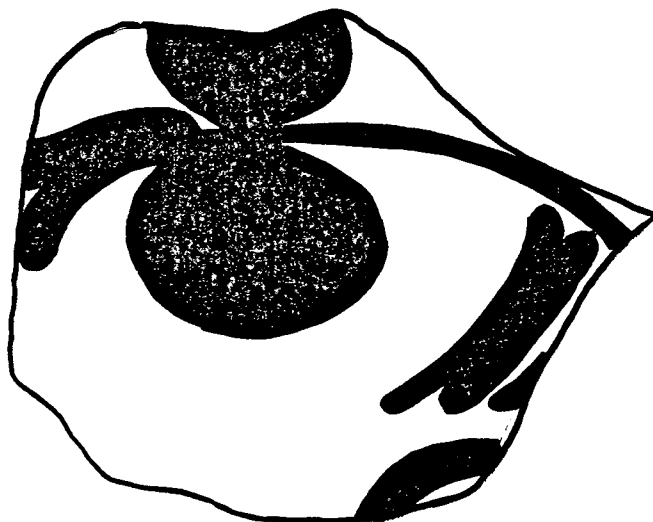
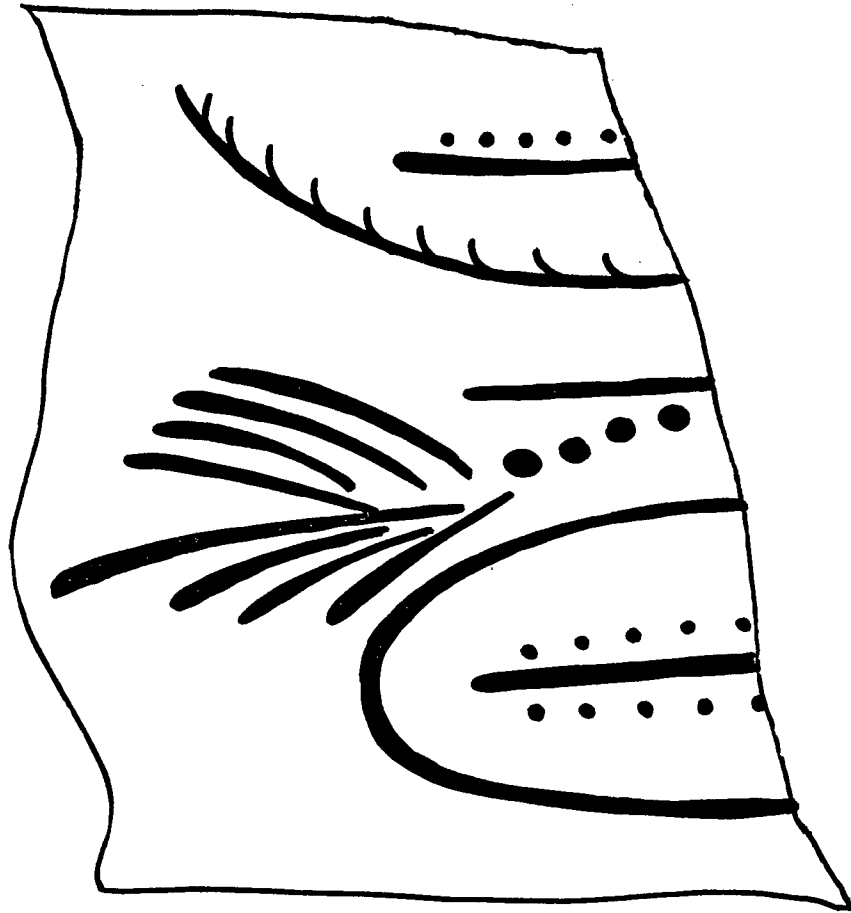

1X

Figure 37. Cobalt blue designs on sherds from 13BN132:
A) Miscellaneous design; B) leaf design

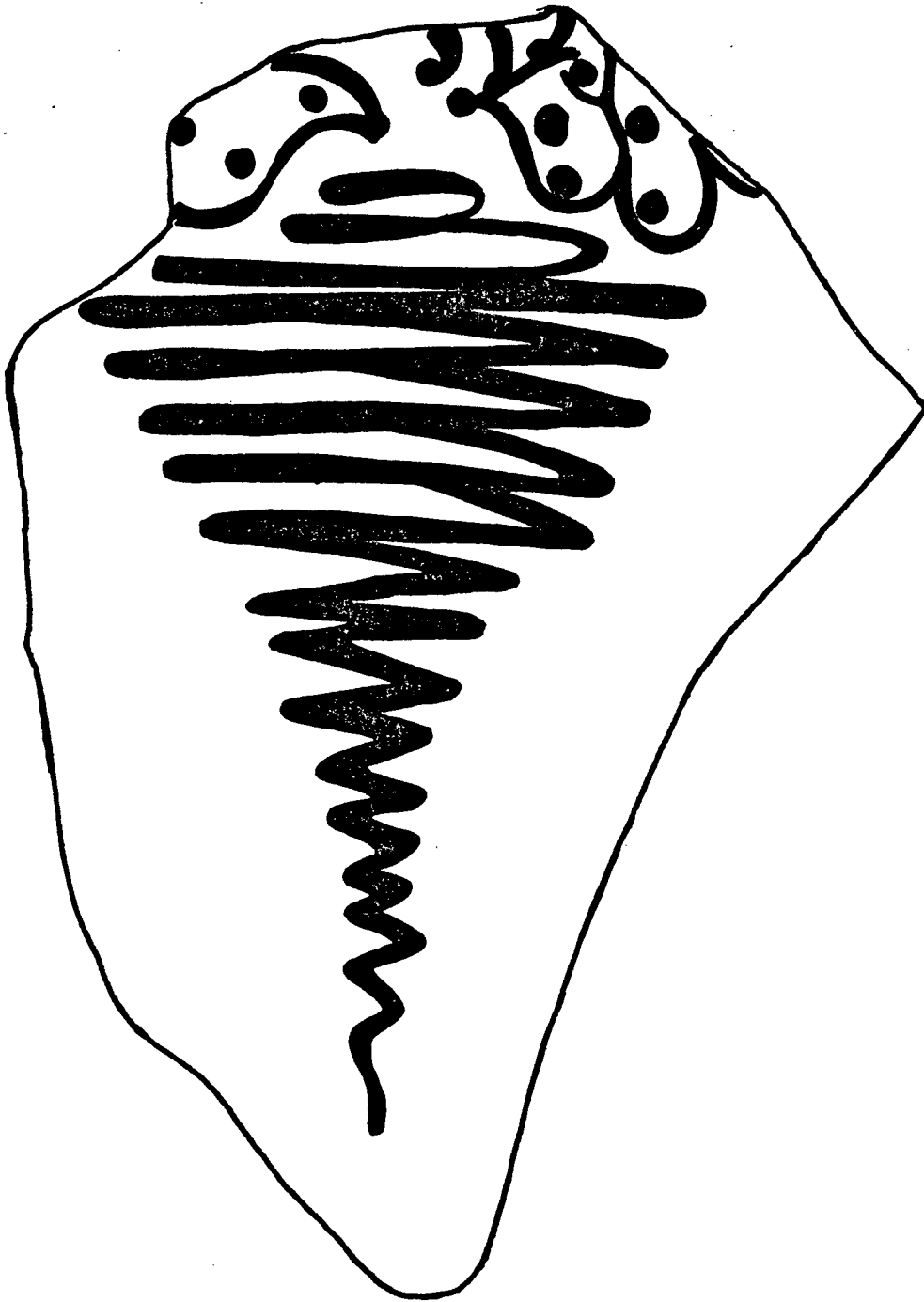

1x

Figure 38. Cobalt blue circle design on sherd from 13BN132

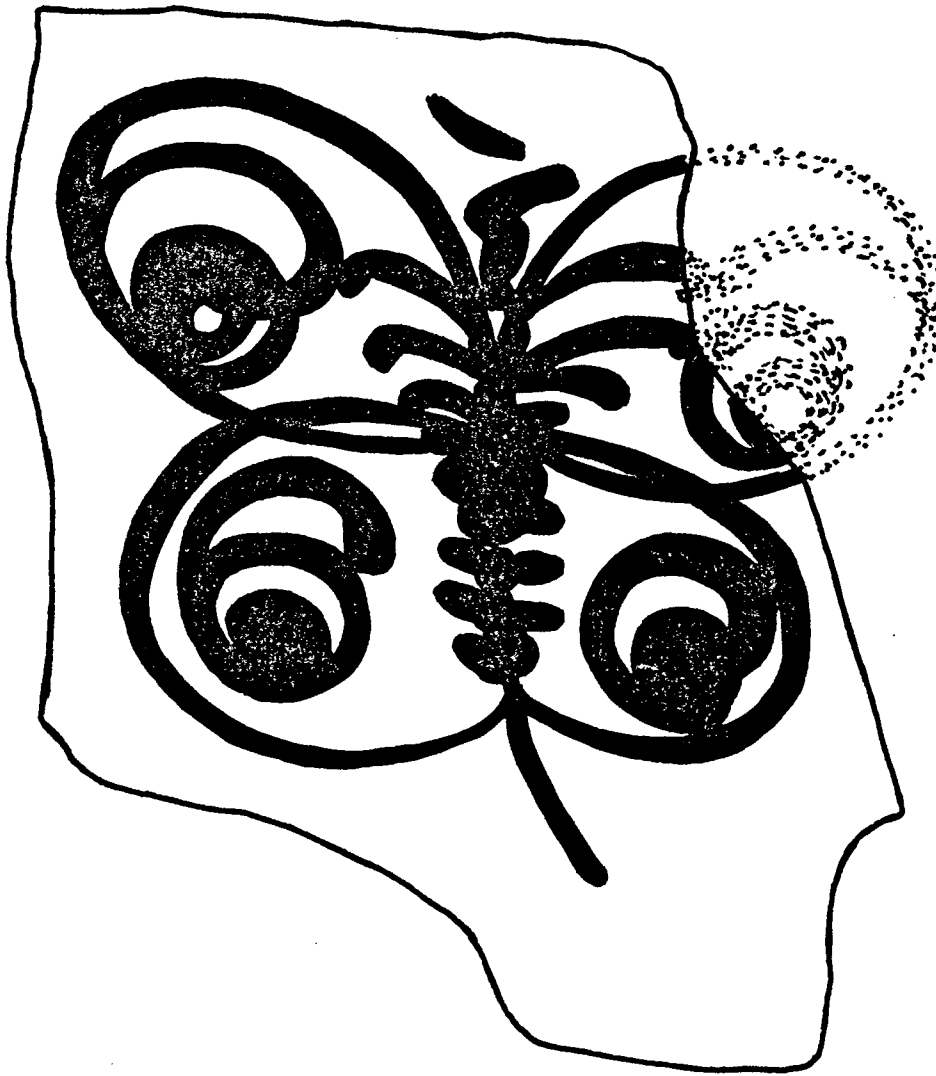

1X

Figure 39. Cobalt blue butterfly design Type A on sherd from 13BN132

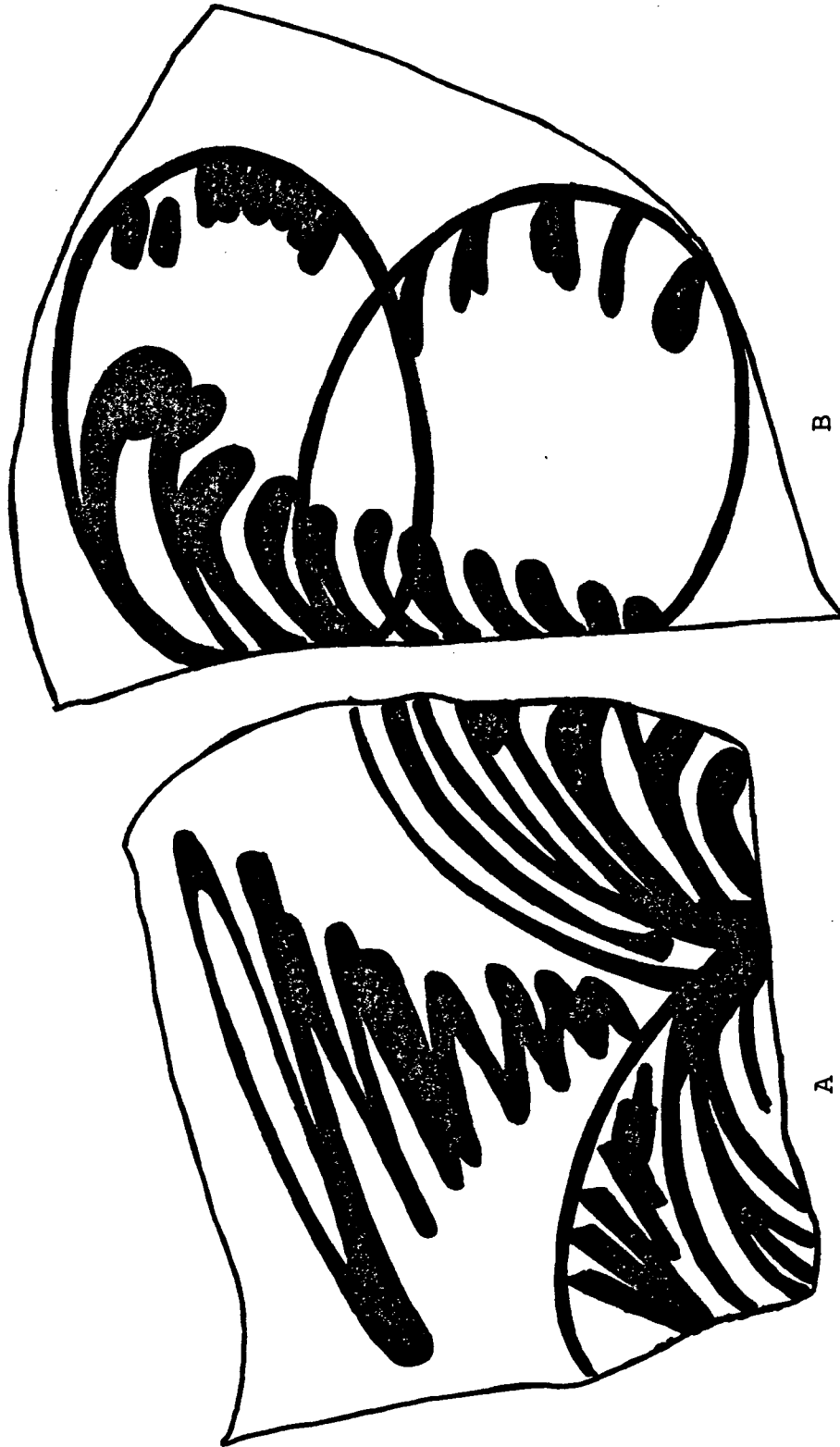

IX

Figure 40. Cobalt blue butterfly design Type B on sherds from 13BN132

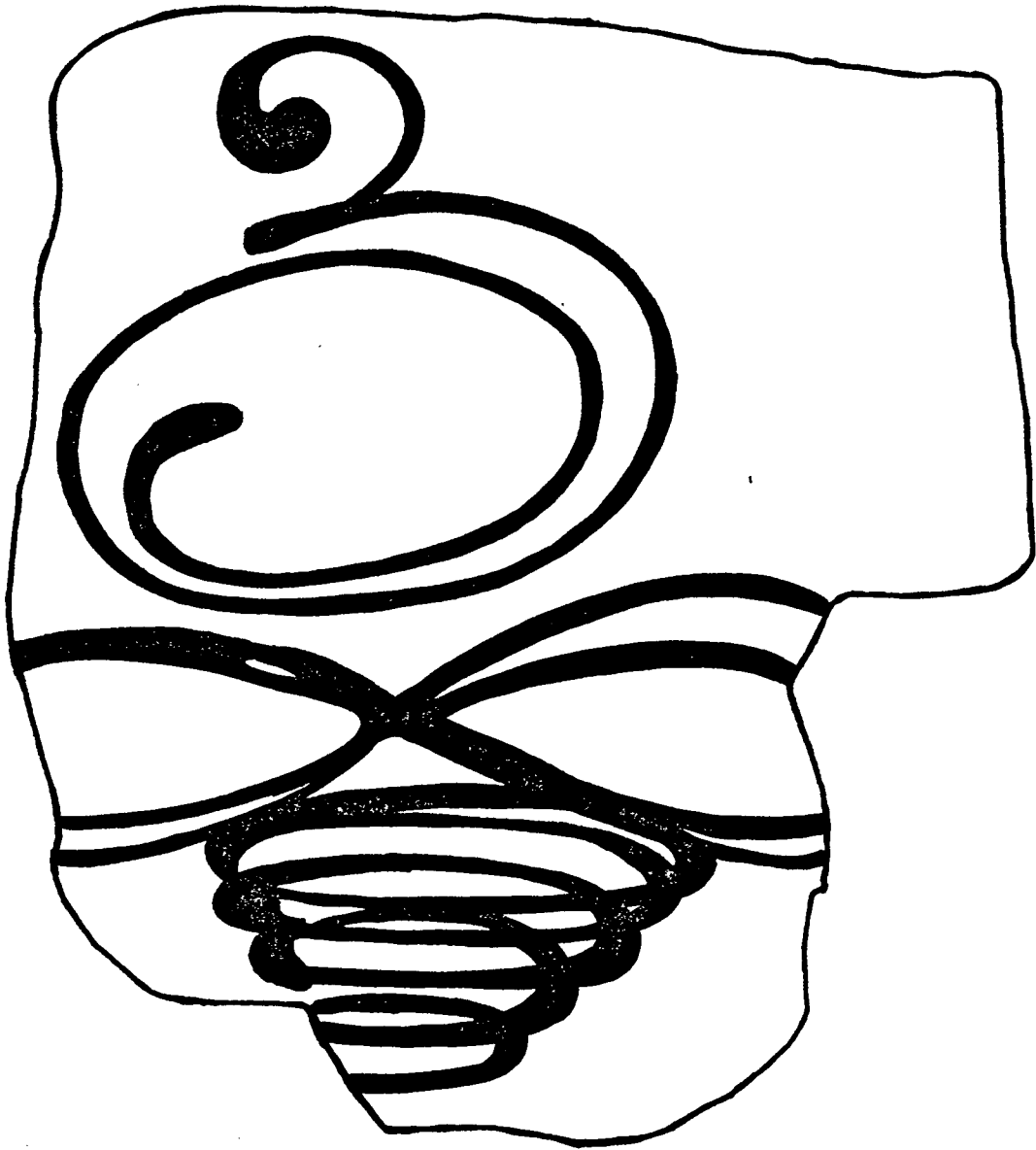

1X

Figure 41. Cobalt blue cyclone design. Type A with script three on sherd from 13BN132

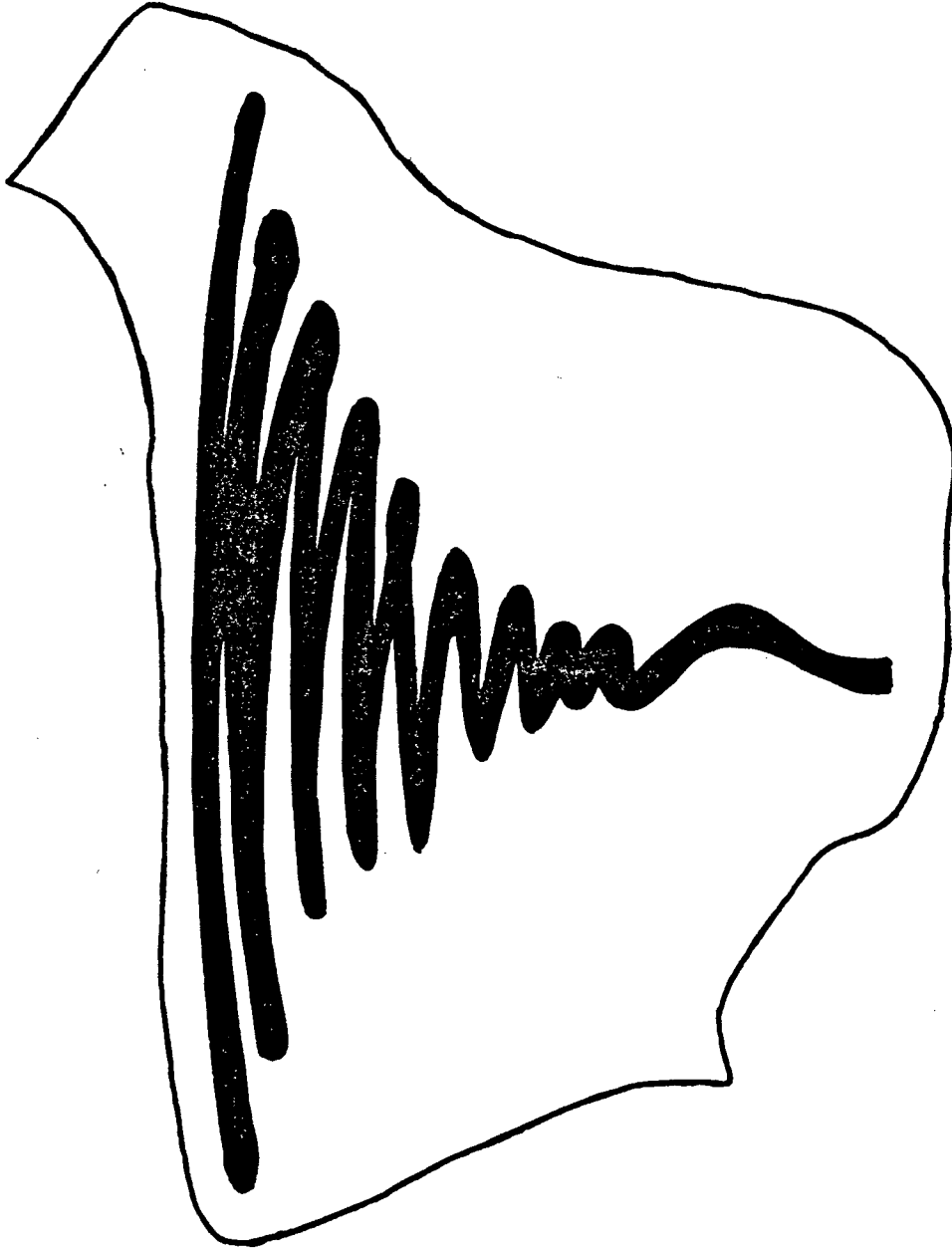

Figure 42. Cobalt blue cyclone design Type B on sherd from 13BN132

designs from 13BN120. One difference between the two sites is in type A, from 13BN132, where the spirals overlap and there is a bow on top of the cyclone. As was previously mentioned a script numeral is sometimes placed on top of a type A cyclone design.

In comparing the designs of the two potteries there are some distinct designs such as the butterfly and circle from 13BN132 and the flower design from 13BN120. When designs are similar, such as cyclones and leaves, there remains some distinctiveness between the two potteries designs. For example the way in which the cyclone type A from 13BN132 is incorporated with the numeral 3 (Figure 41).

There was one large rim-body sherd found in the creek bed at 13BN132. It had a Bristol glaze and a cobalt blue stencil. The measurements of this sherd were as follows: interior rim diameter 434 mm, exterior rim diameter 459 mm, rim thickness 25 mm, rim height 50 mm, and wall thickness 11 mm. The cobalt blue stencil was different from any previously found (Figure 43) and because of this and the type of glaze this sherd may be intrusive from another pottery. There was one other rim sherd that had a Bristol glaze but did not have any cobalt decoration. Because of the small sample size this sherd may also be intrusive.

The analysis of cobalt blue designs is one area that deserves further study, because it may be one of the better

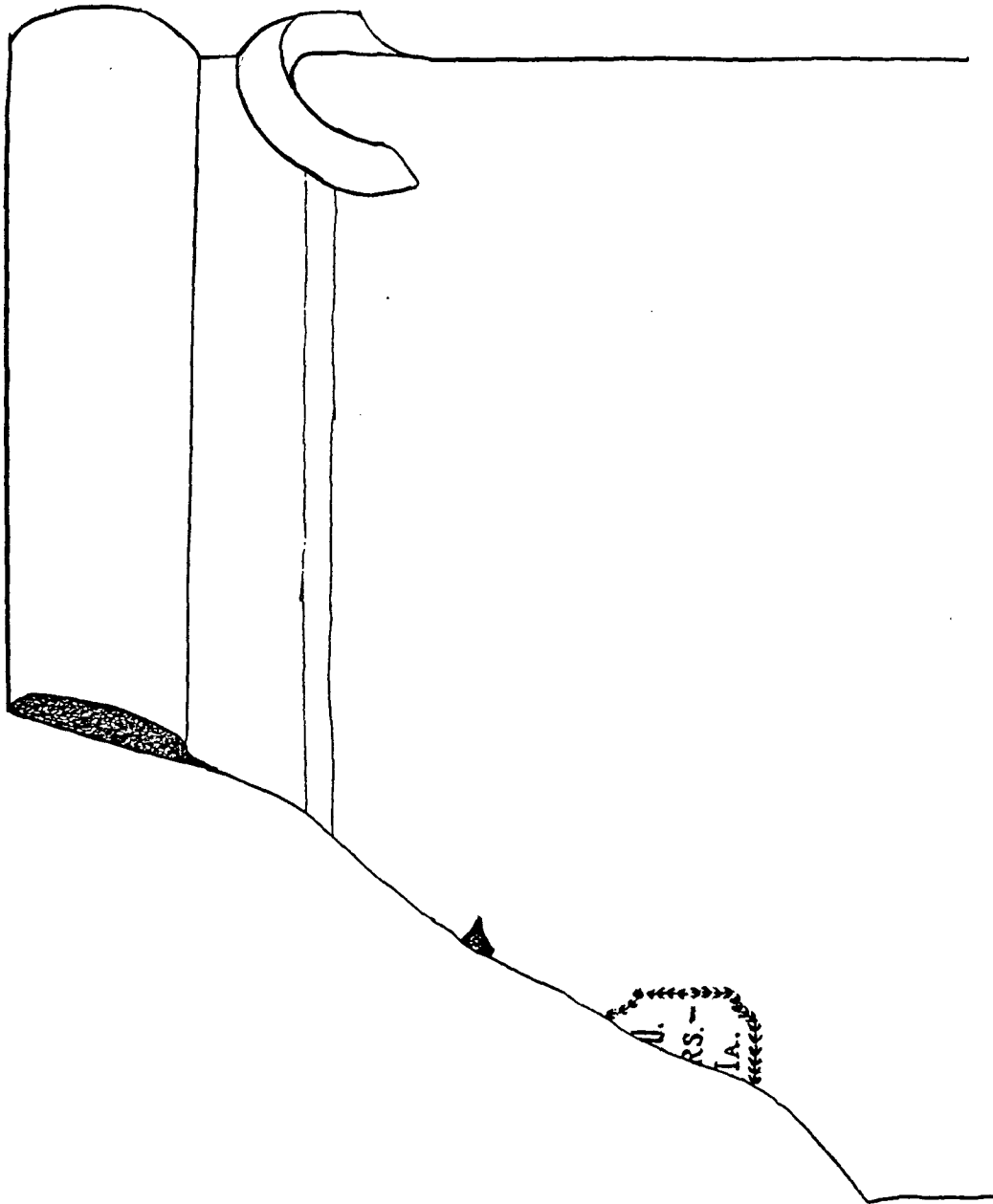

1/4

Figure 43. Large crock sherd with cobalt stencil from 13BN132

ways to distinguish potteries from each other and also to trace the movement of potters from place to place.

Vessel category: churns

A churn is a large diameter covered container with an internal lip for a lid. Churning was a constant household chore because cream was hard to keep before the advent of refrigerators. Butter churns were tall vessels in which cream was agitated to produce butter.

Churn lids were found which seem to fit the internal channeled rims and there were also flat lids which were the same size as some churn lids. This would seem to indicate that there may have been internal channeled crocks. Since there were no complete vessel recovered from either site the term churn is tentatively applied to large diameter rims with internal channels.

Churns had salt glazed exteriors and Albany slipped interiors. They also generally had two "U" shaped handles and one or more striations below the expanded rim.

13BN120 There were 12 churn rims from 13BN120, two of which had cobalt blue markings on them. One of the cobalt blue rims had a slip trailed leaf design and the other had a possible script numeral six. The range of measurements of churns from 13BN120 is as follows:

Internal rim diameter	170-200 mm
External rim diameter	180-220 mm
Diameter of orifice	170-190 mm
Rim thickness	15- 18 mm
Rim height	25- 34 mm
Wall thickness	7- 10 mm

The variations in churn rim forms from 13BN120 are shown in Figure 38.

13BN132 There were 53 churn rims from 13BN132 one of which was an unglazed straight rim. Three rims had cobalt blue markings, two with script numeral fives and the other with a script numeral six. The range of measurements for churns from 13BN132 was as follows:

Internal rim diameter	180-220 mm
External rim diameter	205-240 mm
Diameter of orifice	170-205 mm
Rim thickness	15- 18 mm
Rim height	27- 39 mm
Wall thickness	7- 10 mm

The variations in churn rim forms from 13BN132 are shown in Figure 44.

Vessel category: jars

Jars are small diameter covered containers with internal lips. There were both large and small jars and both sizes had rounded shoulders rather than straight sides. The large jars may correspond to preserve jars, and small jars may be the fruit jars referred to in the order forms for the two potteries.

The large and small jars were probably used to preserve fruits and vegetables. Vegetables such as corn, cabbage,

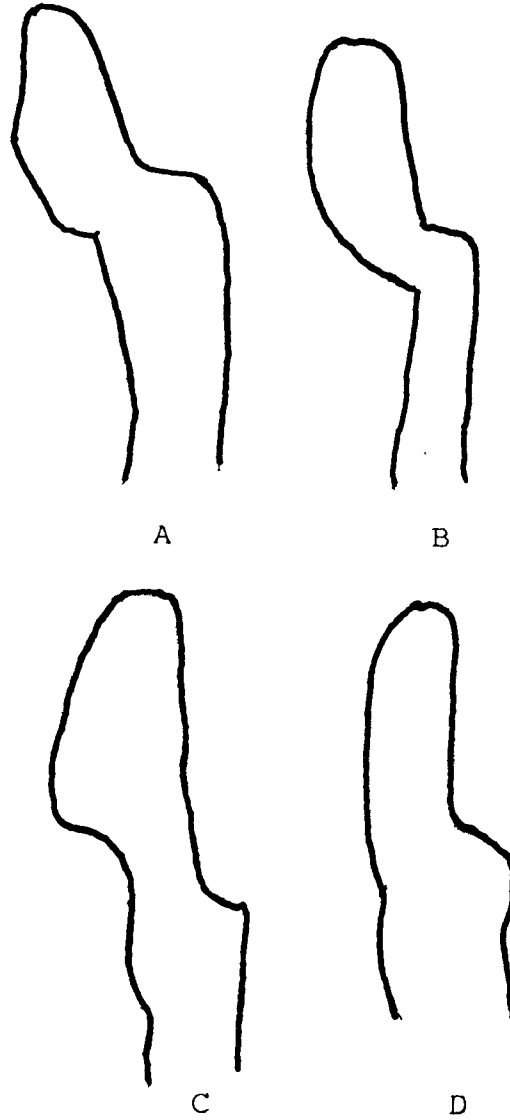

1X

Figure 44. Churn rims: A,B) from 13BN132; C,D) from 13BN120

beans, and beets were pickled in vinegar to be used during the winter. The jars were sealed by first pouring oil, melted butter, or mutton fat over the vinegar brine to keep it from evaporating. The jar was then covered with a lid, leather dust cover, or cloth tied over the rim (Guilland 1971:27).

Fruits were preserved in honey, and sometimes a round of brandied paper was placed directly on the fruit to inhibit the growth of mold. A lid or a dust cover tied over the rim was then sealed with wax or egg white (Guilland 1971:168).

Jars had both salt glazed exteriors and Albany slipped interiors, and Albany slipped interior and exterior surfaces. They generally lacked striations or handles, but the majority of vessels did have a ridge below the rim. A ridge is a slight build up of clay, while a striation is a groove or removal of clay.

Examples of jar rim forms from sites 13BN120 and 13BN132 are shown in Figure 45. Figure 45D may be an example of a rim from an "airtight jar" from 13BN120. Two airtight jar rims were also found at 13BN132. Airtight jars were used much like a glass canning jar. The jar was sealed by placing a piece of cloth, soaked in beeswax, over the mouth of the jar. A circular, concave metal lid was then pressed down over the cloth. Melted wax was then poured over the lid to seal it in place (Guilland 1971:160-161). The following measurements and observations were made on jars from sites 13BN120 and 13BN132:

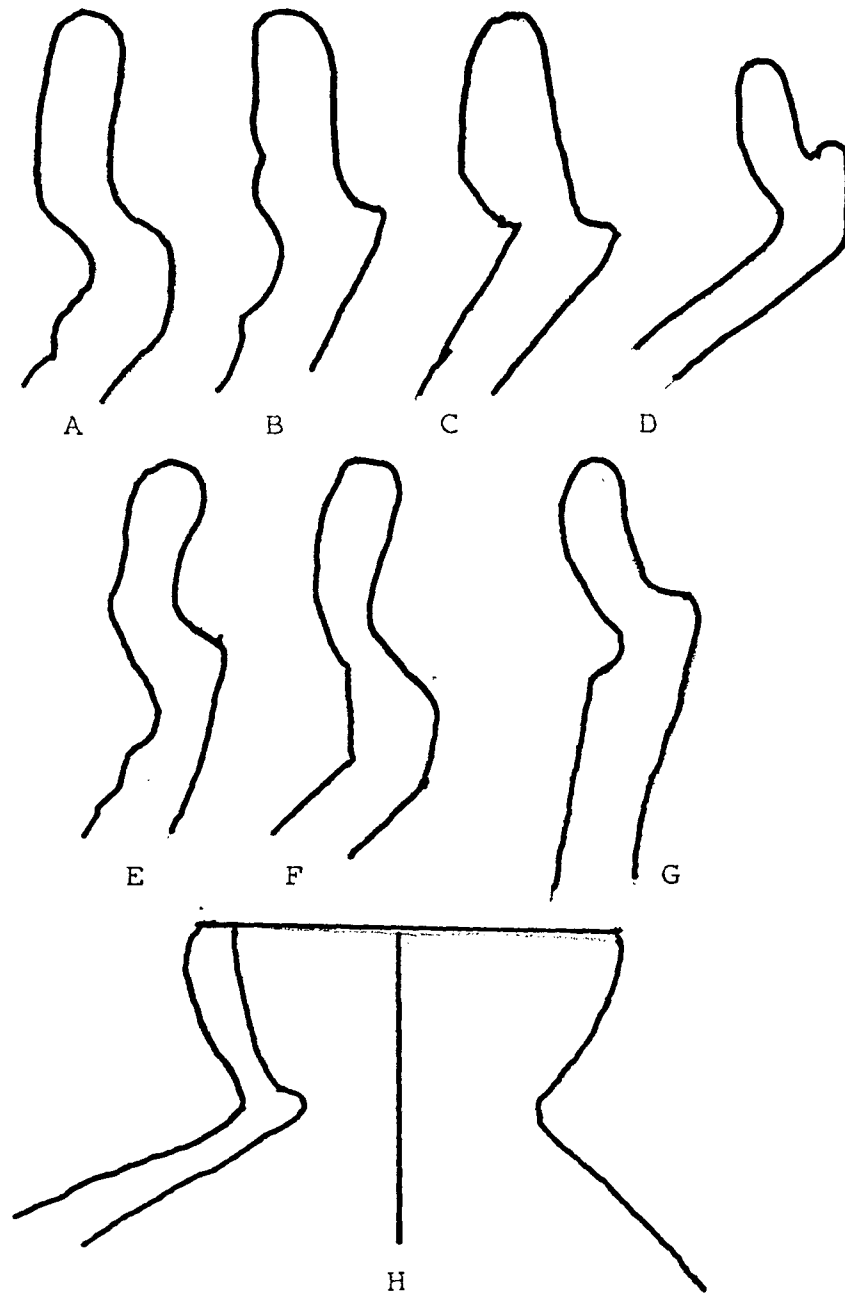

Figure 45. Jar rim forms: A,B,C,D) from 13BN120; E,F,G) from 13BN132; H) half section of jar from 13BN120

1X

	13BN120	13BN132
Internal rim diameter	65-155 mm	92-170 mm
External rim diameter	75-175 mm	106-190 mm
Diameter of orifice	35-135 mm	75-160 mm
Rim thickness	5- 11 mm	5- 12 mm
Rim height	15- 30 mm	16- 34 mm
Wall thickness	5- 9 mm	5- 10 mm

	13BN120	13BN132
Rims with Albany slip exteriors	3	6
with ridges or striations	3	6
plain	1	
Rims with salt glaze interiors		
with ridges or striations	3	14
plain	<u>1</u>	<u>14</u>
	8	20
Airtight jar rims	1	2
Body sherds (from shoulder of jar)		
with Albany slip exteriors	4	10
with salt glaze exteriors	<u>4</u>	<u>10</u>
	8	10

Lids

A variety of lids were found at both sites that represent coverings for crocks, churns, and jars. Pottery lids were available for all sizes of crocks and because they were frequently handled, there was a high rate of breakage. Broken lids were often replaced with a board lid held in place by a rock. Lids were usually not made for any particular pot but in standard sizes that were sold separately and counted as one gallon each in price (Guilland 1971:210). Crock lids were made with a basal ridge or lip to keep the lid in place (Figure 46). Crock lids had either completely salt glazed exteriors or the upper half was dipped in Albany slip. The interiors of the

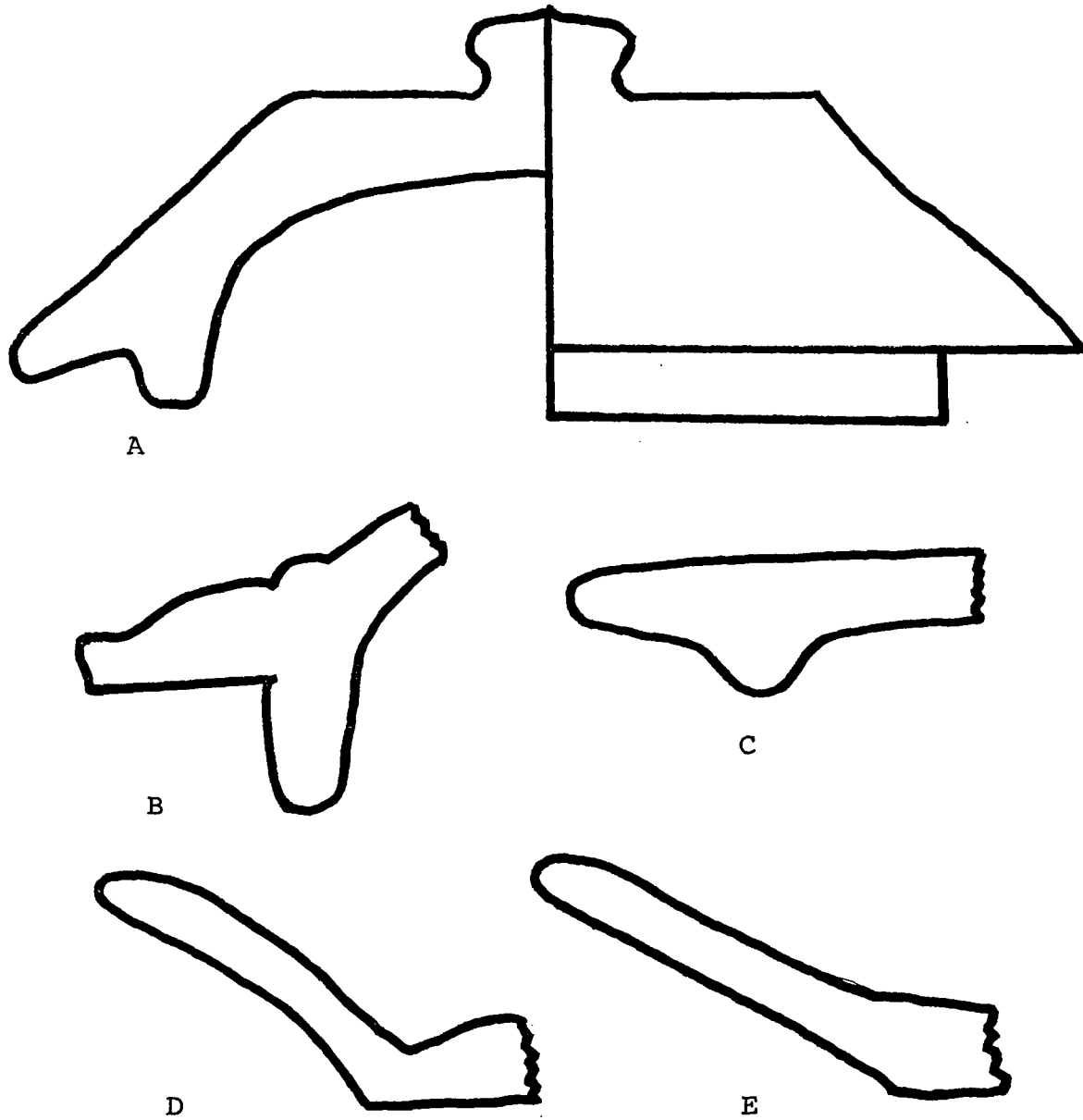

Figure 46. Lid forms: A) crock lid from 13BN132; B,C) crock lids from 13BN120; D,E) jar lids from 13BN120

1/2

lids were either unglazed or Albany slipped. Lids were stacked on top of one another in the kiln and may have been mold made using a jigger and jolly indicated by their uniformity and absence of finger marks. Four crock lids from 13BN132 had numerals stamped on top of them. There were two numeral threes, one four, and one five which probably correspond to the size of crock they fit.

Churn lids were either completely salt glazed or completely Albany slipped. Examples of churn lids are shown in Figure 47.

There was a variety of lids that fit internal channel vessels. The smaller sizes were probably for jars and the larger sizes may have been for crocks with internal channels. Only one of these flat lids was completely Albany slipped the rest were entirely salt glazed. Examples of these lids are shown in Figures 46 and 47. The following list gives the number of lids from each site:

	13BN120	13BN132
Churn lids		
Albany slip surfaces	6	8
Salt glaze surfaces	<u>6</u>	<u>25</u>
		33
Crock lids		
Salt glazed & unglazed	4	22
Salt glazed & Albany	4	8
Unglazed on both surfaces	<u>1</u>	<u>1</u>
	9	30
Jar & internal channel lids		
Salt glazed surfaces	6	34
Albany slipped surfaces	<u>6</u>	<u>1</u>
		35

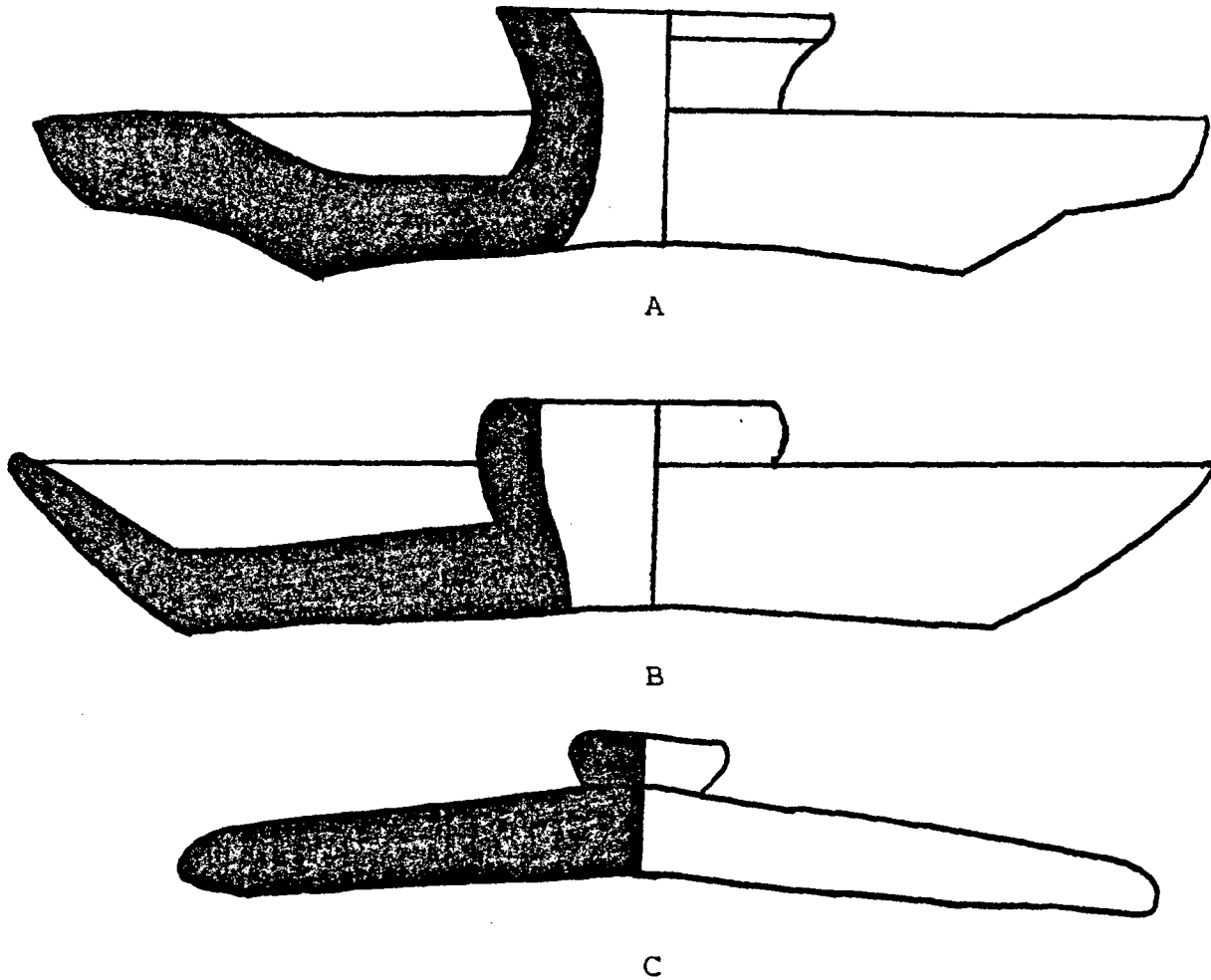

1/2

Figure 47. Lid forms: A,B) churn lids from 13BN120;
C) handled lid for internal channel container
from 13BN132

Vessel category: jugs

Jugs which were used for the storage of liquids were wheel made and had strap handles (Figure 21). Corn, wheat, and rye whiskeys, wine, cider, and vinegar were some of the liquids stored in jugs which were then sealed with a cork or corn cob.

Glaze varied from exterior salt glaze and Albany slip interiors to Albany slipped exteriors and interiors. Figure 48 gives the frequencies of the various types of glazes and also the range of measurements for jugs from sites 13BN120 and 13BN132. The bases of jugs were generally unglazed suggesting they were stacked in the kiln right side up or base to base. One jug rim from site 13BN132 is blocked by a piece of clay that may have been some type of kiln furniture or stacking piece. There were both small and large mouth jugs and the variety of rims are shown in Figures 49 to 51. One small, Bristol glazed jug rim and base was also found in Creek bed with crock shown in Figure 43.

Vessel category: flower pots

Flower pots were generally unglazed or had unglazed interiors and salt glazed exteriors. Three flower pots from 13BN120 and 6 from 13BN132 had salt glazed exteriors while 2 flower pots from 13BN120 and 12 from 13BN132 were unglazed. Flower pots had integral saucer bases and a small drain hole at the base of the pot for draining off excess water from the

	13BN120	13BN132
Small Mouth Jug Rims		
Salt glazed exteriors	15	13
Albany slip exteriors	<u>13</u>	<u>14</u>
	28	27
Large Mouth Jug Rims		
Salt glaze exteriors	2	
Albany slip exteriors	<u>1</u>	
	3	
Body sherds		
Salt glaze exteriors	12	
Albany slip exteriors	<u>20</u>	<u>25</u>
	32	25
Shoulder sherds		
Salt glaze exteriors	18	1
Albany slip exteriors	<u>9</u>	<u>10</u>
	27	11
Base sherds		
Albany slip exteriors	8	8
Handles		
Salt glaze	3	2
Albany slip	<u>3</u>	<u>7</u>
	6	9
Jug neck measurements		
Internal diameter	13-26 mm	18-30 mm
External diameter	38-58 mm	40-58 mm
Height	17-24 mm	11-25 mm
Thickness	9-15 mm	8-15 mm

Figure 48. Table of frequencies and measurements of jugs from 13BN120 and 13BN132

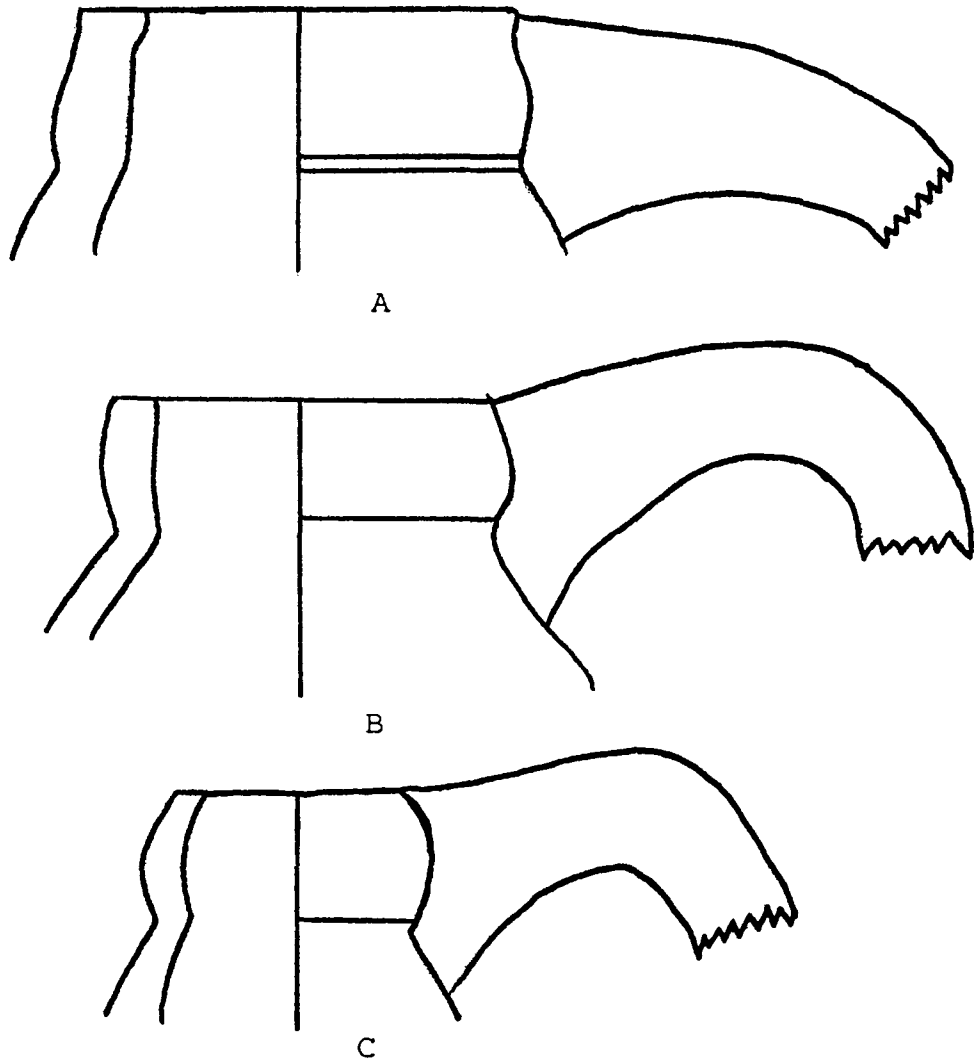

1X

Figure 49. Jug rim forms from 13BN120

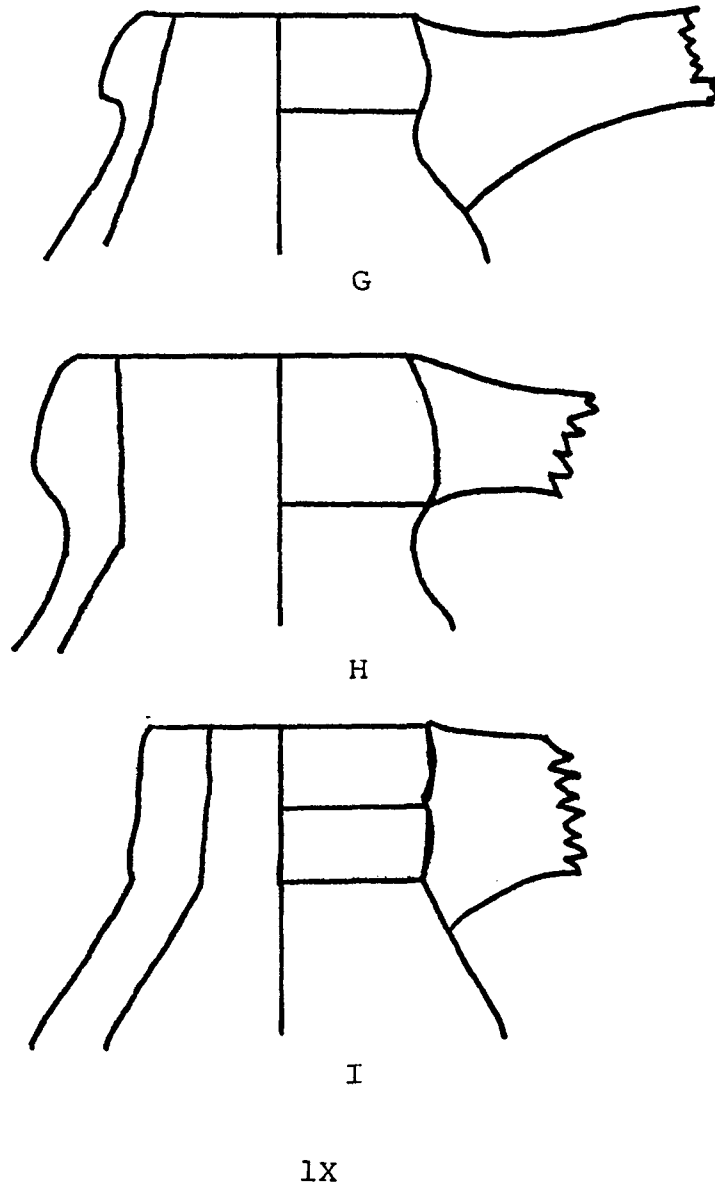
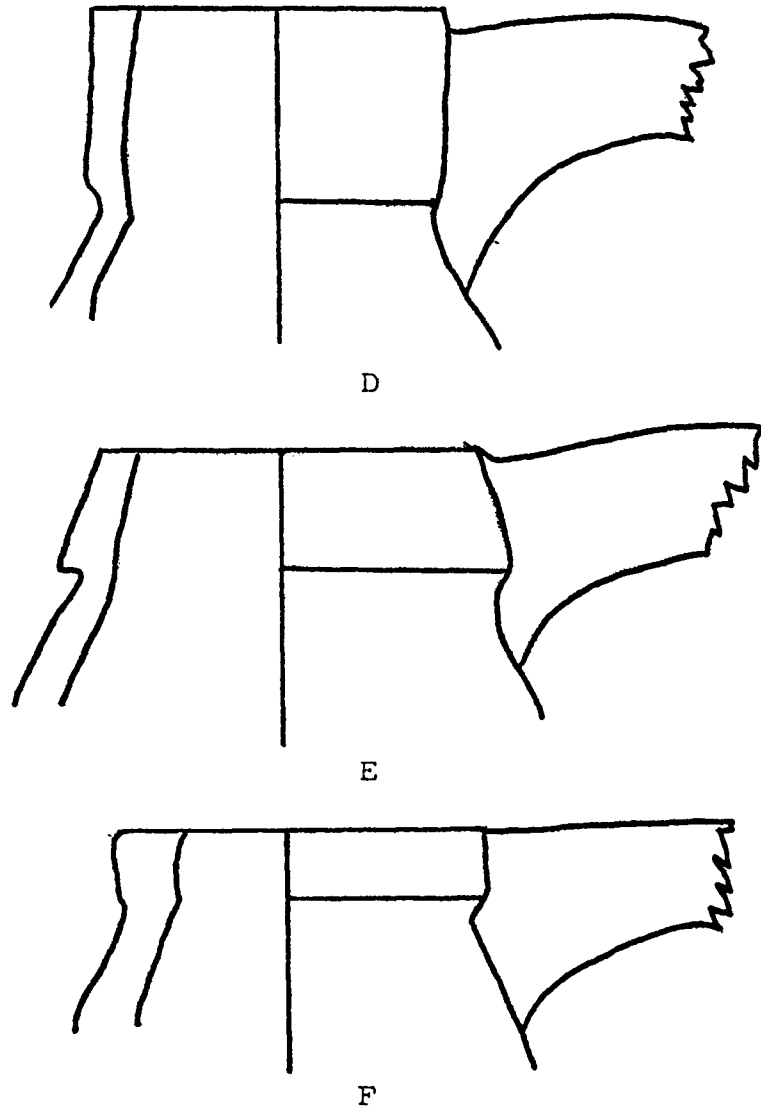

Figure 50. Jug rim forms from 13BN132



1X

Figure 51. Jug rim forms: D,E) from 13BN132; F) from 13BN120

soil (Figure 52). Only one flower pot rim was collected, it was from 13BN120 and was unglazed with a scalloped edge (Figure 52). The range of base diameters from 13BN132 were 85-108 mm, while at 13BN120 the range was 108-140 mm. There were no complete flower pots to accurately correlate the artifacts with the sizes listed on the order forms from the two potteries.

Vessel category: drain tile

Drain tiles were found only at 13BN132 and were used to drain water from agricultural land. A total of 27 tile was collected from 13BN132, 20 were unglazed and 7 had salt glazed exteriors. The Flint Stone Pottery (13BN132) was selling drain tile from two to eight inches in diameter for 2½ to 12½ cents per foot (Boone County Advocate: August 29, 1872) and measurements of the sherds correspond to these sizes. There were three basic types of drain tile (Figure 53).

It is not known how the drain tile was made at the Flint Stone Pottery, but in 1883, the W. C. Shepard Tile Works in Boonsboro made tile in the following manner. Drain tile was made by mixing in a crusher, potter's clay and a low grade of fire clay to give the tile strength. The tile was made in a Hoosier auger machine, which manufactured any size from 2½ to 14 inches in diameter. In a day's time the auger was capable of turning out either 10,000 feet of 3 inch tile, 8,000 feet of 4 inch tile, 6,000 feet of 5 inch tile, or 4,000 feet of 6



A

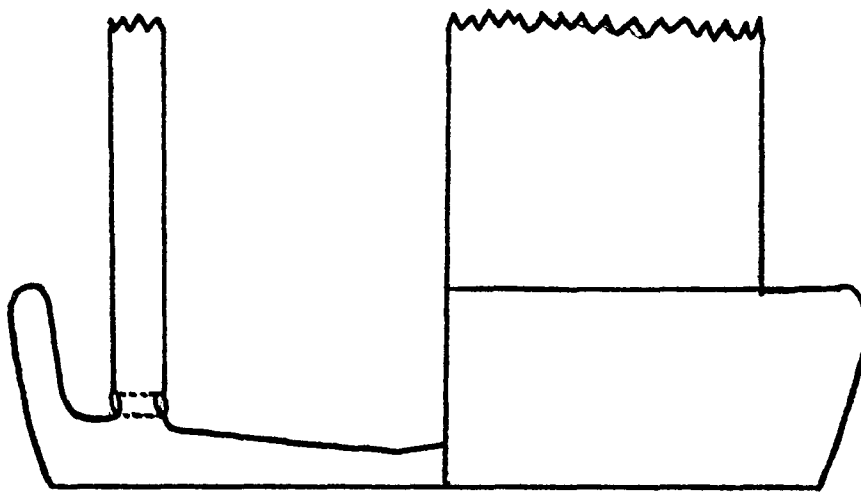

B

1/2

Figure 52. Flower pots from 13BN120: A) scalloped rim profile; B) half section of flower pot

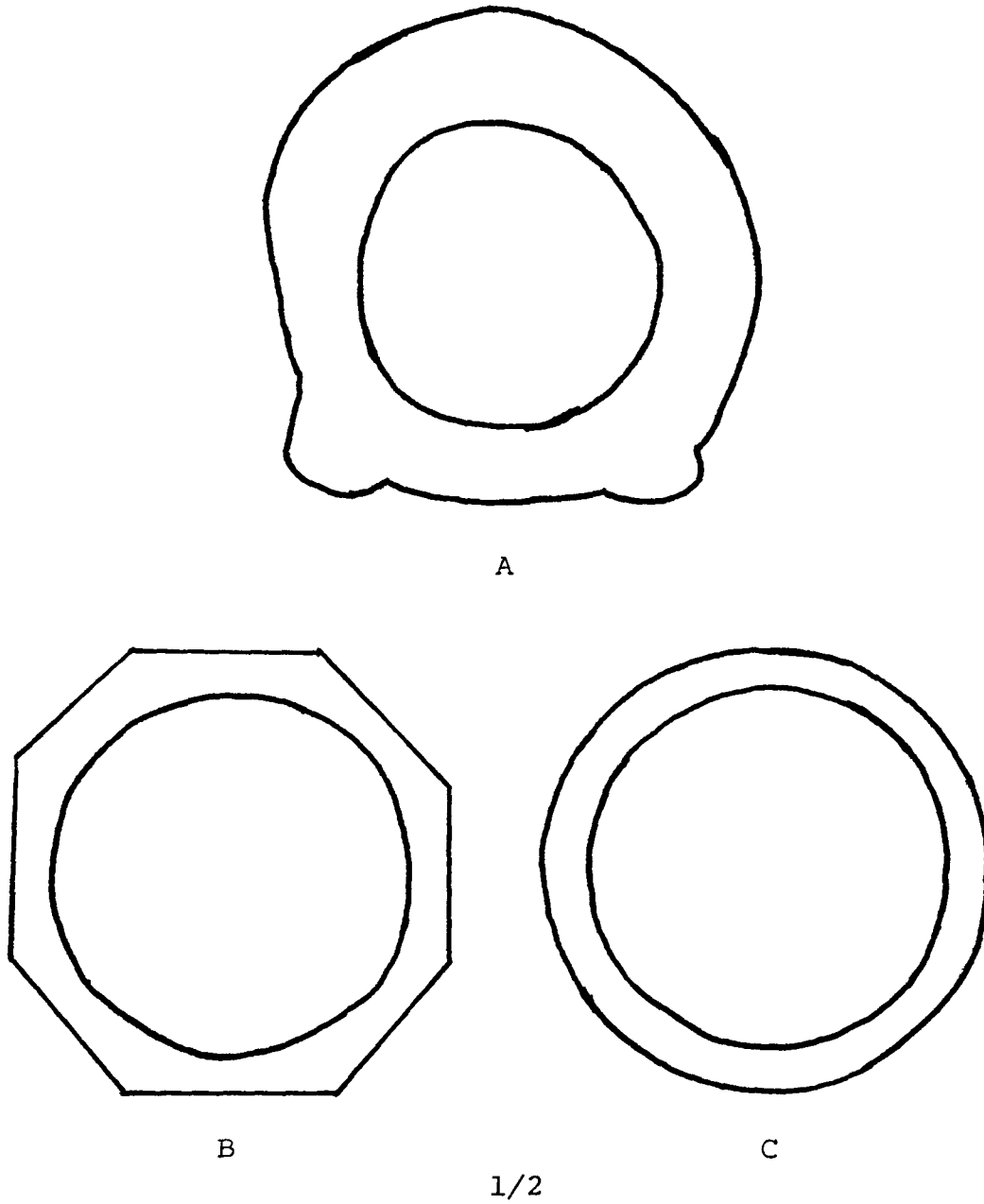

Figure 53. Cross sections of drain tile from 13BN132

inch tile. After coming from the machine the tile was dried in long sheds before being placed in the kilns. About 5,000 bricks were placed in the kiln with the tile in order to use all the space and heat (Boone County Democrat: June 6, 1883). One method of stacking drain tile was to place the smaller tile inside the larger sizes (Dobson 1928:262). The cost for tiling using three inch tile was fifty cents per rod (Boone County Democrat: May 30, 1883).

Miscellaneous vessels from 13BN132

There were several artifacts from 13BN132 that did not fit into the vessel categories previously defined. A description of these artifacts has been included within categories that are meant to suggest possible function.

Water jar This vessel was salt glazed on both exterior and interior surfaces. It had a plain rim, 22 millimeters thick and 32 millimeters high. The diameter of the orifice was 160 millimeters and the walls were 20 millimeters thick (Figure 54A). Although the body and base of the vessel is missing the outward appearance is similar to a water jar from the Coalport kiln (13MA103) (Reynolds 1970:158-159).

Water or feeder pan The bases of two vessels that may be watering pans were found at 13BN132. They had unglazed exteriors and Albany slip interiors. The range of dimensions for the vessels were: base thickness, 20-23 millimeters, wall

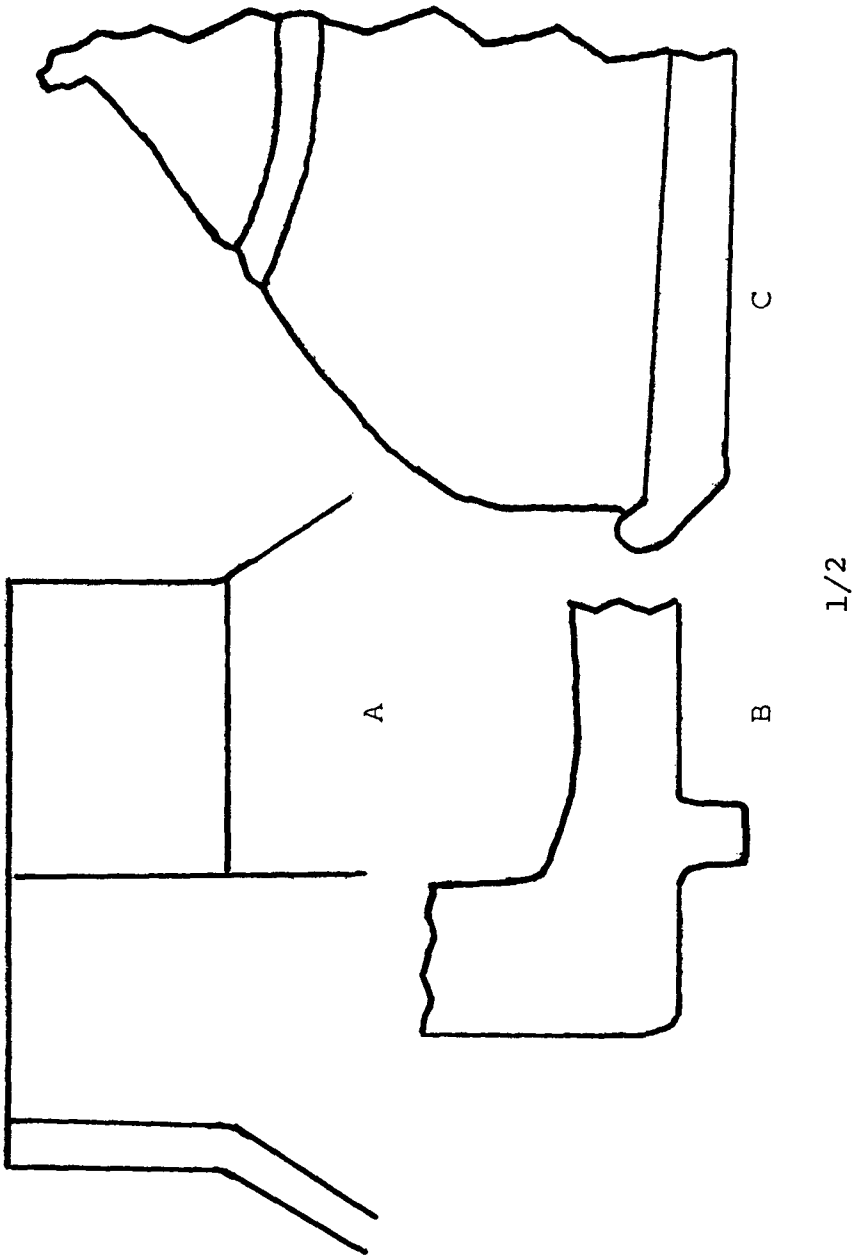

Figure 54. Miscellaneous vessel forms from 13BN132: A) half section of water jar; B) cross section of water pan; C) cross section of spittoon

1/2

thickness, 17-19 millimeters, and base diameter, 280 millimeters (Figure 54B).

Spittoon A vessel from 13BN132 which may be a spittoon had the following dimensions: diameter of base, 195 millimeters, wall thickness, 11-18 millimeters, and base thickness, 10-14 millimeters (Figure 54C).

Well tubing There are two completely salt glazed sherds from 13BN132 that have plain rims and the following dimensions: diameter, 424 mm, rim thickness, 20-24 mm, wall thickness, 15 mm. Two other salt glazed sherds range from, 11-16 mm rim thickness, 11-17 mm wall thickness, and have knife cuts in them. Both types may be some type of well tubing or drain tile (Wilder 1974).

Kiln Furniture

There is very little written about the ceramic industrial waste products or "kiln furniture" which were used to help "set" or stack unfired ware in kilns prior to use. Guillard mentions that

The larger pots and jars were inverted and stacked in staggered tiers, mouth to foot. Small pots were placed inside larger ones, and "picket shaped" setting tiles were used to stack thinner and lighter ware such as pitchers and mugs between rows (Guillard 1971:36).

Stacking the kiln was often done by a specialized person, called a "kiln setter," because this was such an important job

in the manufacture of pottery. The salt glazing process caused the floors and walls of the kiln to become uneven so kiln furniture was used to provide a level surface for stacking the ware. Each time the kiln was set, the kiln setters made new wedges, setting tiles and leveling props from raw clay. The kiln furniture was crudely made by hand and then dipped in sand to prevent it from sticking to the ware which they supported. Most of these pieces were probably used for only one firing and then discarded. Many of these pieces have fingerprint impressions which could possibly be used to identify individual potters. The ware had to be stacked in the kiln as tightly as possible to utilize all the available space and to keep the ware from slumping and warping. At the same time some space had to be left between the ware so that the salt fumes could reach all of the pots, and to prevent the ware from fusing together (Reynolds 1970:163-166).

The following discussion of kiln furniture is based largely on categories used by John Reynolds (1970) in his analysis of the Coalport kiln. His categories have been used whenever applicable to the Moingona potteries and, in a few cases, have been expanded.

Category A

There were 44 examples of large Category A kiln furniture and no small Category A from 13BN120. Ten small and 31 large

Category A pieces were collected from 13BN132. Category A is a hand molded, short squat lump of clay referred to as a "leveling prop." Raw clay was rolled out into cylinders and then one or both ends were squashed flat. Leveling props were used mainly to obtain a level kiln floor and keep the stacks of ware level. These leveling props were placed on the floor of the kiln under the kiln shelves, between the kiln shelves and the first row of ware, and between layers of ware. There was a large and small size of Category A kiln furniture. The large size was 70-120 millimeters wide and 40-66 millimeters high. The small size was 33-80 millimeters wide and 25-57 millimeters high (Reynolds: Plates 18, 19).

Category B

There were 114 examples of Category B collected from 13BN120 and 58 from 13BN132. Category B or "cross-support wedge" is a hand molded cylinder of clay, flattened slightly at each end and dipped in sand. By placing a hand around one of these wedges, one can tell if it was made with the right or left hand. These wedges were used for separating vessels from each other and from the kiln wall. The range of measurements for Category B were 25-36 millimeters wide and 70-118 millimeters high (Reynolds: Plate 18).

Category D

Category D or "irregular flat elongated setting tiles" are rectangular to ovoid in shape. These flat tiles were handmade and dipped in sand and were used to place pots rim to rim and perhaps rim to base of vessels that had diameters that were very close in size (Figure 47). There were three sizes of Category D, a large ovoid shape, a medium rectangular shape, and a small rectangular shape. The large size was 50-88 millimeters wide, 13-14 millimeters thick, and 73-125 millimeters long. For the medium size the length and thickness was similar to the large size but the width was 38-52 millimeters. The small size was 18-23 millimeters wide and 8-11 millimeters thick. The following list gives the frequencies of Category D pieces from each site;

	13BN120	13BN132
Large ovoid	123	4
Medium rectangular	201	62
Small rectangular	54	
	<u>378</u>	<u>66</u>

Category E

There were 148 Category E pieces from 13BN120 and 47 from 13BN132. Category E are handmade, sand dipped cylinders of clay that have been bent to form a ring. In most cases the entire ring is not found. These pieces were apparently used in setting pots on the lowest level of the kiln, or they could also have been used between the floor of the kiln and kiln

shelves as leveling props. The range of measurements were 49-66 millimeters wide and 22-38 millimeters thick (Reynolds: Plate 20, Figure 55A).

Category F

Category F or "kiln shelves" are wheel made circular slabs of clay that were fired before use. There are two types of Category F. The first size was 54-59 millimeters thick with a diameter between 260-320 millimeters. There were 20 examples of this type from 13BN120 and 16 from 13BN132. Two of the examples from 13BN120 have the numeral "2" stamped on them. Sometimes there are irregularly cut holes in the center of these pieces, which may have allowed the hot gases of the kiln fire to circulate. The second type of kiln shelf was 28-32 millimeters thick with diameters from 200-290 millimeters. There were 47 examples of this type from 13BN132 and 1 from 13BN120. Many of these pieces have a dished out area in the center that may have been used for the purpose of circulating hot air and salt fumes. Category F kiln shelves were leveled by placing leveling props such as Category A and E between the shelves and the floor of the kiln. There were several examples from both sites in which leveling props were stuck to one side of the kiln shelves and setting tiles were stuck to the other side of the shelves (Reynolds: Plates 10, 19).

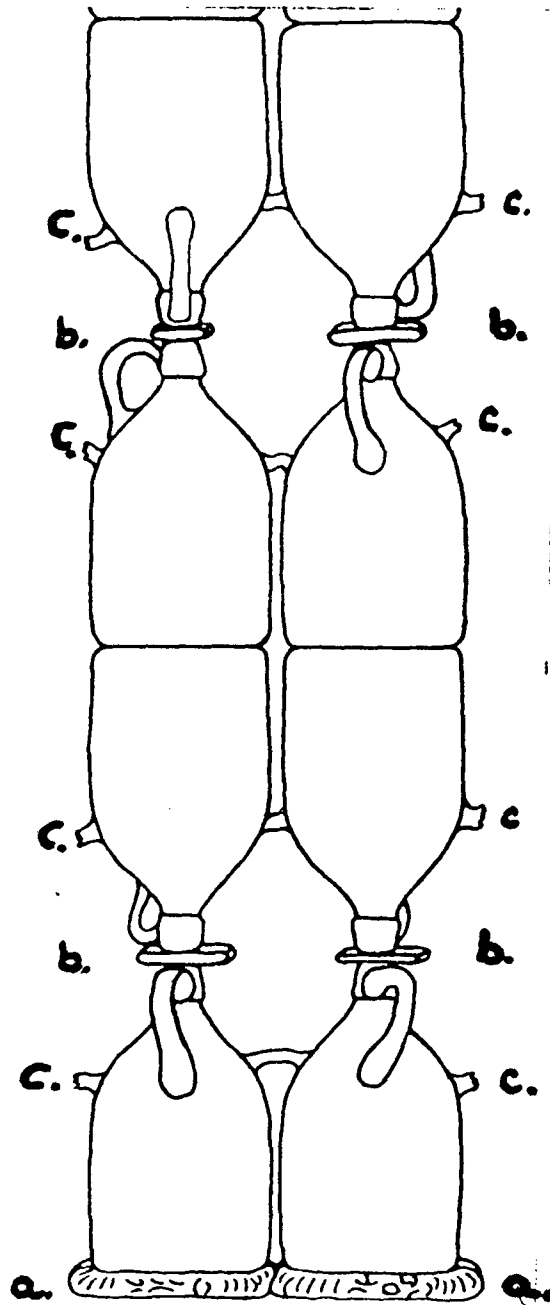

Figure 55. Positions of kiln furniture: A) ring on which stack is based; B) disc between the necks of jugs; C) wedges to separate the vertical stacks (Webster 1971:163)

Category H

There were two examples of Category H at 13BN120 and none at 13BN132. Category H are small disks of clay 10-15 millimeters thick and 50-60 millimeters in diameter used to separate vessels from each other in firing. These pieces are handmade and sand dipped and were probably used for stacking small jars and jugs (Figure 55B). The mouth of one jug from 13BN132 was blocked with a piece of clay that may be a Category H disk (Reynolds: Plates 20, 23).

Category K

There were five examples of Category K collected from 13BN120 and none from 13BN132. Category K are cylindrical to flat pieces of clay that have been bent in the middle to an angle past a right angle. The pieces are handmade and sand dipped and were probably used to separate vessels from one another in stacking the kiln. The measurements for Category K were 30-60 millimeters wide and 25-50 millimeters high (Reynolds: Plate 20, Figure 55C).

In addition to the above types of kiln furniture there were 43 pieces of miscellaneous kiln furniture from 13BN120 and 55 pieces from 13BN132. Some kiln furniture was stuck together which provided information about methods of stacking. There were 18 examples of this compound kiln furniture from 13BN120 and 12 from 13BN132.

Miscellaneous artifacts

There were several types of artifacts that do not fit the kiln furniture categories previously defined but are associated with the firing process and have been included under a miscellaneous artifact category.

Draw trial and cut and glazed sherds Draw trials were pieces of pottery with a hole cut in them to facilitate their removal with an iron hook from the kiln during firing. They were used to test the temperature of the kiln and to determine if the glazing was proceeding properly. Daniel Rhodes (1957: 150) comments on the use of draw trials,

Draw trials are sometimes used as an aid in judging when a firing is complete. Small rings of clay may be set up in the kiln inside the spy-hole. These rings are made of the same clay and coated with the same glazes as the pots in the kiln. When the cones are bending, the rings are drawn out with an iron rod, dipped in water to cool, and examined for fusion and maturity of glaze. Sudden cooling prevents draw trials from giving much idea of what the final color of the glazes will be, but they do give a good indication of how far melting has proceeded. Before the invention of the pyrometric cone, draw trials were the chief means of judging when a firing was finished.

There were 7 draw trials from 13BN120 and 5 from 13BN132. The majority of draw trials from both sites were wedges cut from a milk pan. Starting from the top of the rim to about two inches below the base of the rim, a hole was then cut in the wall of the wedge (Figure 56). Sixteen cut and broken sherds were also recovered from 13BN120, the edges of which show

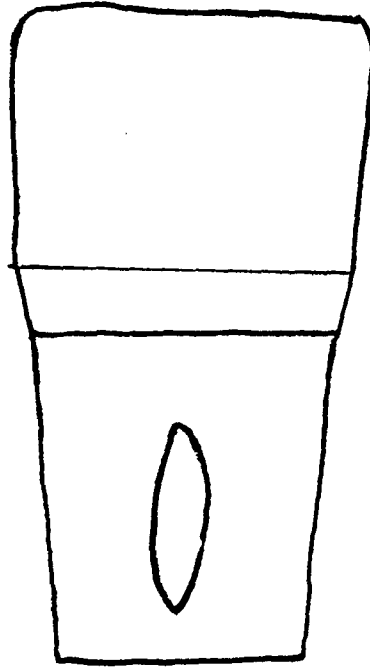

1X

Figure 56. Draw trial made from a cut rim section of a milk pan from 13BN120

evidence of salt glazing and were probably used as draw trials, or they may have been part of vessels broken during firing.

Salt glazed cylinders There were three salt glazed and one unglazed cylinders of clay from 13BN120 that do not fit any of the categories previously described. They were not sand dipped and are better made than, for example, category B which are also cylindrical in shape. They may be some form of stilt used to add strength to a stack of ware. The ends are broken off, so it is unknown if they had sand on them to prevent sticking to ware. These cylinders were 20-28 millimeters wide and 28-90 millimeters long.

Non-kiln Associated Artifacts

A number of artifacts were found at these two sites which were indicative of the general historic settlement of the area. These artifacts are not directly related to the manufacture of pottery in Moingona but they do provide information about some of the household items being used during the latter part of the nineteenth century. Because of time limitations these artifacts will not be analyzed at the present time. Instead, a list of these artifacts is provided, with their analysis planned for some later time.

13BN132 (Flint Stone Pottery)

China

- 1 plate sherd with raised blue design
- 1 light blue sherd with flower design on one side
- 2 base sherds

Glass

- 1 clear octagonal bottle base with DESIGN PATENTED 10 and the number 5122 written on it
- 1 neck/shoulder junction of clear glass bottle
- 2 light green bottle necks
- 1 clear bottle base with number 26 on bottom
- 1 dark green square bottle base
- 1 clear highly scratched sherd

13BN120 (Moingona Pottery Works)

China

- 1 doll's head
- 1 marble

Clay

- 1 clay pipe bowl
- 1 clay fragment-possible piece of pipe bowl

Glass

- 2 rose colored sherds

Plastic

- 1 button, probably recent

Shell

- 3 pieces of shell

Stone

- 2 flint spalls--possibly indicative of an earlier Indian occupation

Metal

- 1 curved, thin piece of metal, disk shaped

CHAPTER SIX: G. W. CHANDLER COLLECTION

Material of G. W. Chandler provided a major source of information in terms of the archival data previously presented and in terms of Chandler's pottery and patents on ceramic inventions. Chandler's material is important because it provides a direct link to the manufacture of pottery in Moingona and gives a unique insight into the archival and archaeological date not found in any other sources. The material is in the possession of Mrs. Eloise Anderson, a granddaughter of G. W. Chandler. Most of the pottery was probably made for his own use rather than for sale. There is no evidence that he made the ware while working in Moingona, but the pottery has been included because of his role in the Moingona potteries and because they are complete vessels.

Pottery and Associated Material

Pottery

The pottery in Mrs. Anderson's possession includes a dinner plate, pie pan, pitcher, angel food cake pan, butter dish, butter churn, toy bank, and a variety of milk pans, mixing bowls, and small jars with lids. Three pieces of pottery that were rather unique were the pitcher, angel food cake pan, and butter dish (Plate 2). There were also a variety of flower pots which ranged from a small Albany glazed

pot with appliqued flower designs to larger pots with scalloped edges and pedestal bases (Plate 3). These flower pots appear to be more highly decorated than any found at 13BN120 or 13BN132, which is consistent with the idea that they were made by Chandler for his personal use rather than for sale. Figure 57 lists the frequencies and measurements of the various types of vessels in Mrs. Anderson's possession.

Potter's wheel

A potter's wheel used by Chandler is also in Mrs. Anderson's possession (Plates 4 and 5). The dimensions of the frame and wheel are as follows:

Wooden Frame

sides 18X29 inches
back 19X29 inches
platform $17\frac{1}{2} \times 16\frac{1}{2}$ - 23 inches from ground

Iron Wheel

diameter of throwing wheel $9\frac{1}{2}$ inches
shaft height $22\frac{1}{2}$ inches
diameter of kick wheel $16\frac{1}{2}$ inches

Wooden Treadle

$23\frac{1}{2}$ inches long
 $4\frac{1}{2}$ inches high

Stencil

There is also a tin stencil of the numerals 0 through 9 that was used to mark, in cobalt blue, the number of gallons a vessel held (Figure 58). The dimensions of the stencil are as follows: 294 millimeters long, 65 millimeters wide, and the numbers are 27 millimeters high.

<u>Milk pans or mixing bowls</u>					
	1	2	3	4&5	
Diameter of rim	254 mm	241 mm	161 mm	102 mm	
Rim thickness	14 mm	10 mm	11 mm	7 mm	
Rim height	36 mm	straight	26 mm	18 mm	
Base diameter	140 mm	188 mm	91 mm	60 mm	
Total height of vessel	130 mm	93 mm	78 mm	49 mm	
Exterior & interior glaze	Albany	Albany	Albany	Bristol	
<u>Crocks</u>					
	1	2	3	4	
Diameter of rim	165 mm	119 mm	80 mm	75 mm	
Rim thickness	16 mm	11 mm	10 mm	10 mm	
Base diameter	196 mm	149 mm	106 mm	93 mm	
Total height of vessel	210 mm	158 mm	111 mm	124 mm	
Exterior & interior glaze	Salt	Albany	Salt	Albany	
<u>Jars</u>					
	1	2	3	4	
Interior rim diameter	78 mm	82 mm	80 mm	74 mm	
Diameter of orifice	66 mm	71 mm	69 mm	63 mm	
Exterior rim diameter	105 mm	120 mm	102 mm	96 mm	
Base diameter	105 mm	115 mm	92 mm	94 mm	
Total height of vessel	142 mm	133 mm	155 mm	150 mm	
Interior glaze	Albany	Albany	Albany	Albany	
Exterior glaze	Salt	Salt	Albany	Albany	
<u>Churn</u>					
Rim diameter	240 mm				
Base diameter	250 mm				
Total height of vessel	435 mm				
Salt glaze exterior	Albany slip interior				
<u>Jar lids</u>					
	1	2	3	4	5
Diameter	90 mm	100 mm	86 mm	110 mm	99 mm
Glaze	Salt	Salt	Albany	Albany	Salt
<u>Churn lids</u>					
	1	2			
Diameter	223 mm	196 mm			
Glaze	Albany	Albany			
<u>Jug (unfired)</u>					
Interior rim diameter	13 mm				
External neck diameter	35 mm				
Rim thickness	7 mm				
Rim height	14 mm				
Base diameter	103 mm				
Total height of vessel	150 mm				

Figure 57. Table of measurements of ceramic material of G. W. Chandler from collection of Mrs. Anderson

Pitchers

	1	2
Diameter of rim	150 mm	115 mm
Rim thickness	12 mm	11 mm
Base diameter	145 mm	157 mm
Total height of vessel	212 mm	150 mm

Both are completely Albany slipped

Pie pan

Diameter of rim	285 mm
Thickness	10 mm
Base diameter	210 mm

Salt glaze surface

Dinner plate

Diameter	257 mm
Thickness	7 mm

Albany slip surface

Angel-food cake pan

Rim diameter	248 mm
Rim height	65 mm
Rim thickness	10 mm
Base diameter	196 mm
Width at top of cone	12 mm
Width at base of cone	20 mm

Albany slip surface

Toy bank

Base diameter	57 mm
Total height	112 mm
Width of slot	25 mm
Width of knob at top of bank	27 mm

Albany slip surface

Butter dish and cover

Diameter of cover	165 mm
Thickness of cover	7-37 mm
Height of cover	65 mm
Diameter of handle	31 mm
Diameter of dish	190 mm
Thickness of dish	5 mm

Dish- Albany slip
Cover- Albany slip with unglazed band on shoulder

Figure 57. (Continued)

<u>Hanging basket flower pots</u>	1	2		
Length of orifice	190 mm	186 mm		
Length of base	170 mm	130 mm		
Width of orifice	123 mm	115 mm		
Width of base	100 mm	16 mm		
Height	95 mm	90 mm		
Wall thickness	19 mm	7 mm		
Cobalt blue flecks and salt glaze surface				
<u>Large flower pots</u>	1	2	3	4
Total height	250 mm	195 mm	230 mm	236 mm
Orifice diameter	191 mm	155 mm	190 mm	210 mm
Base diameter			80 mm	
Saucer diameter	123 mm	125 mm		126 mm
Base height	25 mm	35 mm	60 mm	58 mm
Rim thickness	10 mm	7 mm	10 mm	12 mm
Raised decorations	X			
Scalloped rim		X	X	X
Scalloped base			X	X
Glaze on rim	Albany	Albany	Salt	Albany
Glaze on body	Albany	Bisque	Salt	Albany
Glaze on base or saucer	Albany	Albany	Salt	Albany
Interior glaze	Albany	Albany	Unglazed	Albany
<u>Small flower pots</u>	1	2	3	4
Total height	141 mm	121 mm	149 mm	137 mm
Orifice diameter	140 mm	110 mm	121 mm	131 mm
Base diameter			91 mm	
Saucer diameter	129 mm	77 mm		101 mm
Base height	21 mm	20 mm		27 mm
Rim thickness	7 mm	10 mm	13 mm	10 mm
Raised decoration	X			
Scalloped rim				
Scalloped base				
Glaze on rim	Albany	Albany	Salt	Albany
Glaze on body	Albany	Bisque	Salt	Bisque
Glaze on base	Albany	Bisque	Salt	Albany
Interior glaze	Albany	Albany	Unglazed	Albany

Figure 57. (Continued)

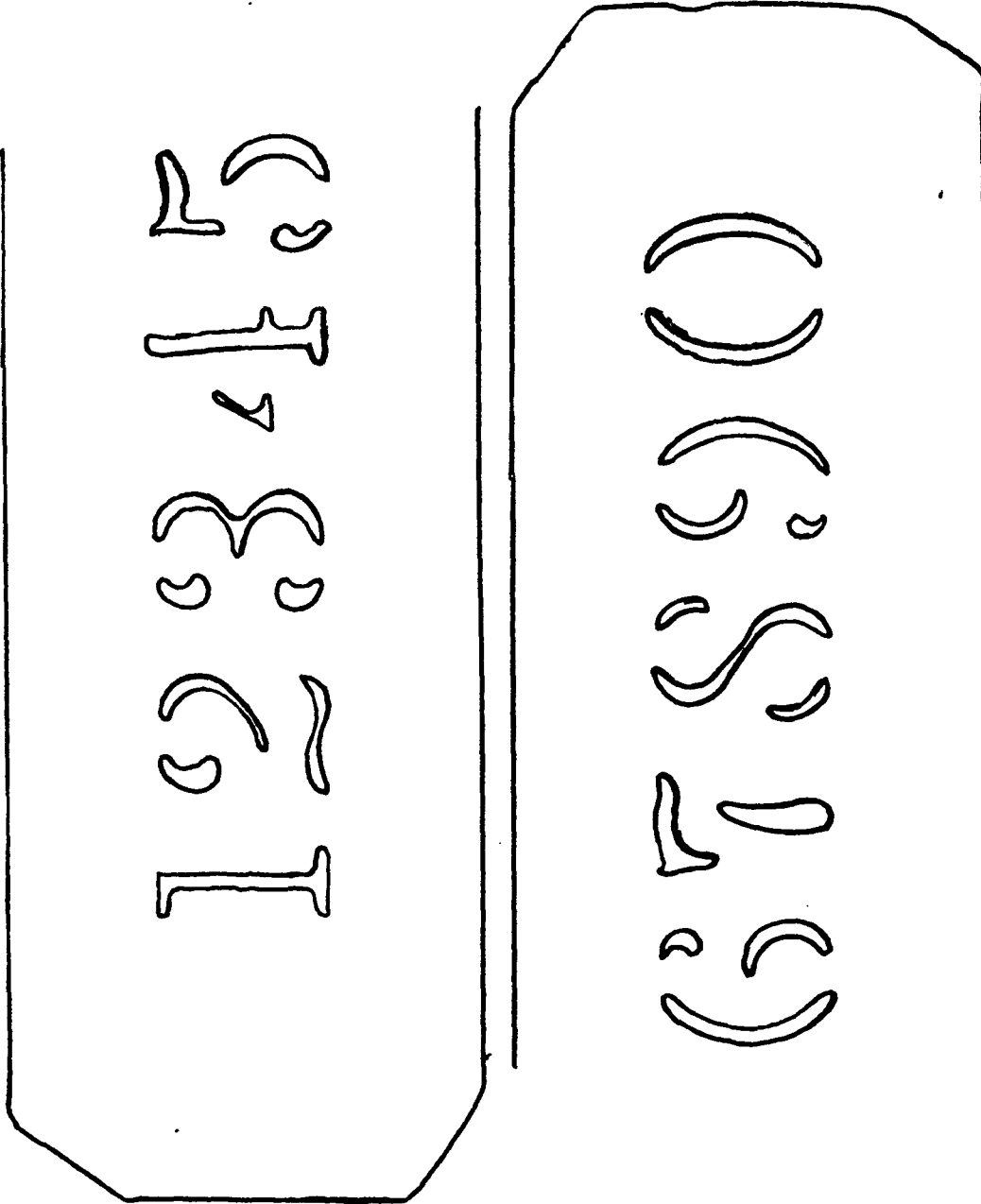

Figure 58. Number stencil of G. W. Chandler from Mrs. Anderson's collection

Inventions and Patents

G. W. Chandler was an inventor of clay products and an article from the Boone County Democrat on June 8, 1881, (see page 33) mentioned that he was making clay balls to shoot at as targets.

Ceramic shoe heels

Chandler made ceramic shoe heels, with the holes for nails made in the heel before they were fired (Figure 59). The heel was unglazed except for the edge, which had an Albany slip. It is not known if the bottom of the heel had a leather covering or was left unadorned.

Ceramic railroad tie

On January 30, 1877 Chandler received a patent for a ceramic railroad tie (Figures 60-61). A newspaper account in June of 1877 mentioned this invention:

G. W. Chandler, Esq. of the Moingona Pottery, has invented a new railroad tie, made of potter's clay, and has received a patent for the same. We were shown a full-sized sample a few days since. The tie is composed of sections about a foot long with groves for strap iron, and bolt holes between the sections by means of which they are to be fastened firmly together. The sections are about eight inches thick and burned as hard as flint. If the pieces will stand the jar the invention is going to prove a good thing. Some railroad men who have seen the samples think that they will prove a success. If they will stand the jar there will be no end to their durability, and while the cost may be more than the wood tie, yet the matter

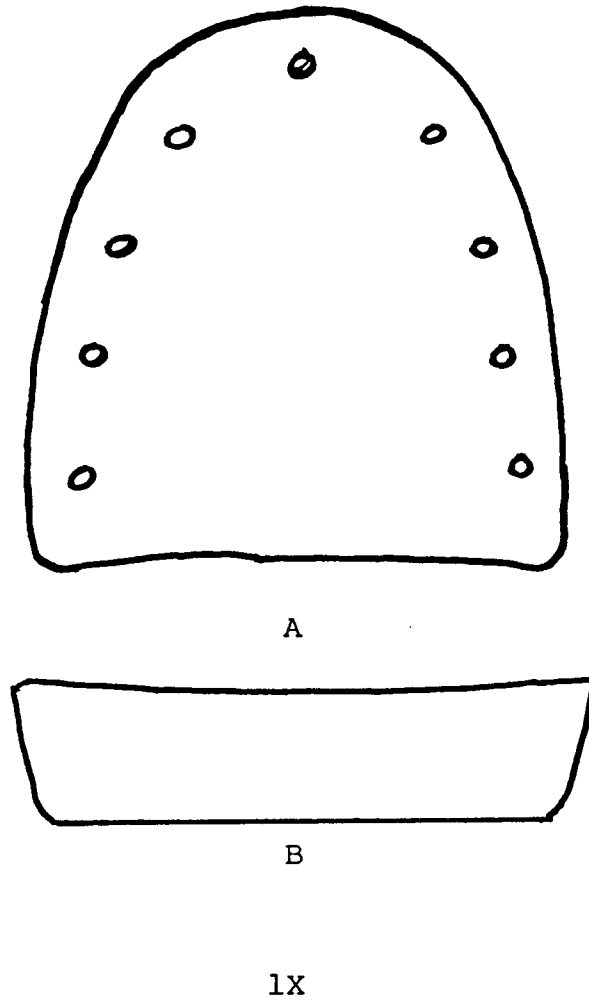

Figure 59. Ceramic shoe heel from collection of Mrs. Anderson:
A) bottom view; B) cross section

UNITED STATES PATENT OFFICE.

GEORGE W. CHANDLER, OF MOINGONA, IOWA.

IMPROVEMENT IN RAILROAD-TIES.

Specification forming part of Letters Patent No. **186,710**, dated January 30, 1877; application filed December 30, 1876.

To all whom it may concern :

Be it known that I, GEORGE W. CHANDLER, of Moingona, in the county of Boone and State of Iowa, have invented a new and Improved Railroad-Tie, of which the following is a specification :

In the accompanying drawing, Figure 1 represents a top view, and Fig. 2 a vertical longitudinal section, of my improved railroad-tie.

Similar letters of reference indicate corresponding parts.

The invention relates to an improved railroad-tie of cheap and durable construction, to be used as a substitute for the wooden cross-ties; and it consists of a tie constructed of clay or stone blocks, connected by longitudinal iron straps bolted together, the straps carrying fastening-plates for supporting the rails.

In the drawing, A represents brick-shaped pieces or blocks of clay, stone, or other material, of which two or more are employed to form one cross-tie. The pieces A are connected by iron straps B, which are fastened together at the ends and between the pieces A by screw-bolts C, the bolts being seated in suitable end recesses of the same. The iron straps B are seated in longitudinal grooves formed in the blocks A, extending from end to end, so as to be flush with the top and bottom surface of the same.

The tie may be made of any length for double tracks, crossings, &c., by merely lengthening the iron straps and inserting as many bricks or blocks A as required, as many

intermediate screw-bolts being used at the adjoining ends of the blocks as required by the number of the same.

To impart a certain degree of elasticity to the tie, the bricks or blocks may be placed a few inches apart, which renders them slightly yielding to the rolling-stock, and overcomes the difficulty experienced with stone ties on account of their rigidity.

Fastening-plates D, with raised lips *a*, fitting the base of the rails, are secured by one or more screws, *b*, to the iron straps, the plates D sliding by side flanges or guides along the straps until they are in the position required by the rails. The cross-ties are very strong and durable, and intended to be used in place of the wooden sleepers, which are getting more and more expensive, especially in sparsely-wooded sections of the country.

Having thus described my invention, I claim as new and desire to secure by Letters Patent—

1. A railroad cross-tie constructed of clay or stone blocks, connected by longitudinal iron straps and fastening-bolts, substantially in the manner and for the purpose set forth.

2. The combination of the longitudinally-grooved clay or stone pieces with iron fastening-straps, seated in the grooves, and with end and intermediate screw-bolts, substantially as specified.

GEORGE WM. CHANDLER.

Witnesses:

L. A. CASWELL,
A. P. DANALDSON.

Figure 60. Patent on railroad ties from Mrs. Anderson's collection

G. W. CHANDLER.
RAILROAD TIES.

No. 186,710.

Patented Jan. 30, 1877.

Fig. 1.

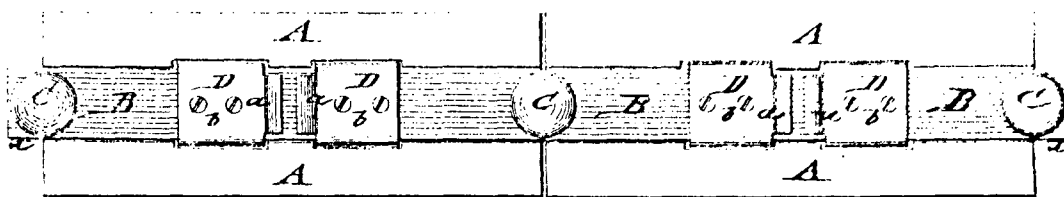
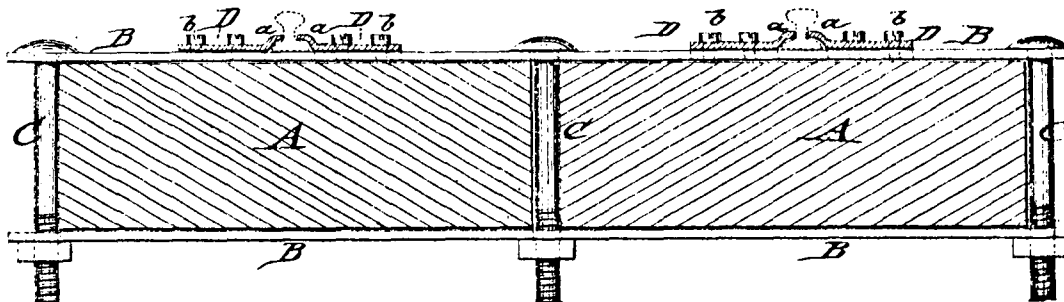

Fig. 2.



WITNESSES:

James M. McClellan
J. H. Scarborough

INVENTOR:

G. W. Chandler

BY

Wm. H. [Signature]

ATTORNEYS.

H. PETERS, PHOTO LITHOGRAPHER, WASHINGTON, D. C.

Figure 61. Illustration of railroad tie from Mrs. Anderson's collection

of durability will overbalance that ten times. It is probable that some of these ties will soon be placed in the Boone yard for trial (Boone County Republican: June 13, 1877).

Ceramic fence post holder

On August 24, 1877 G. W. Chandler and S. H. Deering, his partner in the Moingona Pottery Works, received a patent on a ceramic fence post holder (Figures 62 and 63).

Even after Chandler had moved to Des Moines in 1884, he was not content to retire from the pottery business and so opened "The Potter's Wheel" where he charged people ten cents to watch him throw ware on a wheel. The vessels he made were probably never glazed or fired but used only for demonstration purposes (Anderson 1974).

Chandler was continually experimenting with ways to expand the uses of clay. The experimentation may have been his response to the continuing decline of the pottery business, and was Chandler's way of trying to keep the business alive. Adaptive strategies of this type were common on the frontier where economic survival often depended upon being versatile at a number of different skills and occupations.

UNITED STATES PATENT OFFICE.

GEORGE W. CHANDLER AND SYLVESTER H. DEERING, OF MOINGONA, IOWA.

IMPROVEMENT IN FENCE-POSTS.

Specification forming part of Letters Patent No. **196,561**, dated October 30, 1877; application filed August 24, 1877.

To all whom it may concern:

Be it known that we, GEORGE WILLIAM CHANDLER and SYLVESTER HOBERT DEERING, of Moingona, in the county of Boone and State of Iowa, have invented a new and useful Improvement in Fence-Posts, of which the following is a specification:

Figure 1 is a front view of our improved fence-post, the base being shown in section. Fig. 2 is a detail view of the iron part of the post, turned one-quarter around.

Similar letters of reference indicate corresponding parts.

The object of this invention is to furnish an improved post for fences which shall be simple in construction, and which will not sag, and cannot be heaved or thrown out by the frost.

A is a rod, of iron, of suitable size and length, according to the purpose for which the post is to be used. B is the base of the post, which is made bell-shaped, and with a cylindrical enlargement upon its lower end, forming a shoulder. The lower end of the base B is closed with a bottom plate, C, which has a flange upon its upper side, fitting into the mouth of the base B. The base B and cap-plate C are made of clay, baked hard, in the manner of earthenware. Through the top of the base B and the center of the bottom plate C are formed holes, through which the post A passes, and is secured in place by a nut, a^1 , screwed upon its lower end, and by lips a^2 formed upon it, which rest upon a washer, a^3 , placed upon the top of the base B.

When the post A B C is to be set, the base B is to be filled with earth, to make it heavy and anchor it more securely in the ground.

In Fig. 1 the post is represented as being used for a wire fence. In this case the fence-wires D cross the post at suitable distances apart, and are secured to it by a small wire, E, which is passed several times around the post A, below the lower wire D, is passed around the wire D at each side of the post A, is then taken up to the next wire D, is passed around the wire D at both sides of the post A, is taken up to the next wire, and so on to the top wire D, where it is again passed a number of times around the post. The post A, just below the lower wire D and just above the upper wire D, has lips or notches a^4 formed in it, to prevent the coils of the wire E from slipping up or down.

When the post is used as a hitching-post, it should have a hole formed through its upper part to receive the hitching-strap.

When the posts are used for fencing cemetery-lots, yards, &c., the posts A should have a hole formed in their upper part to receive the chain.

Having thus described our invention, we claim as new and desire to secure by Letters Patent—

The base B, made of hard-burnt clay, in the shape of a bell, with a cylindrical projection around its lower part, and provided with a burnt-clay bottom plate, C, in combination with the iron rod or post A, substantially as herein shown and described.

GEORGE WILLIAM CHANDLER.
SYLVESTER HOBERT DEERING.

Witnesses:

A. P. DONALDSON,
REUBEN DEERING.

Figure 62. Patent on fence post holder from Mrs. Anderson's collection

G. W. CHANDLER & S. H. DEERING.
Fence-Posts.

No. 196,561

Patented Oct. 30, 1877.

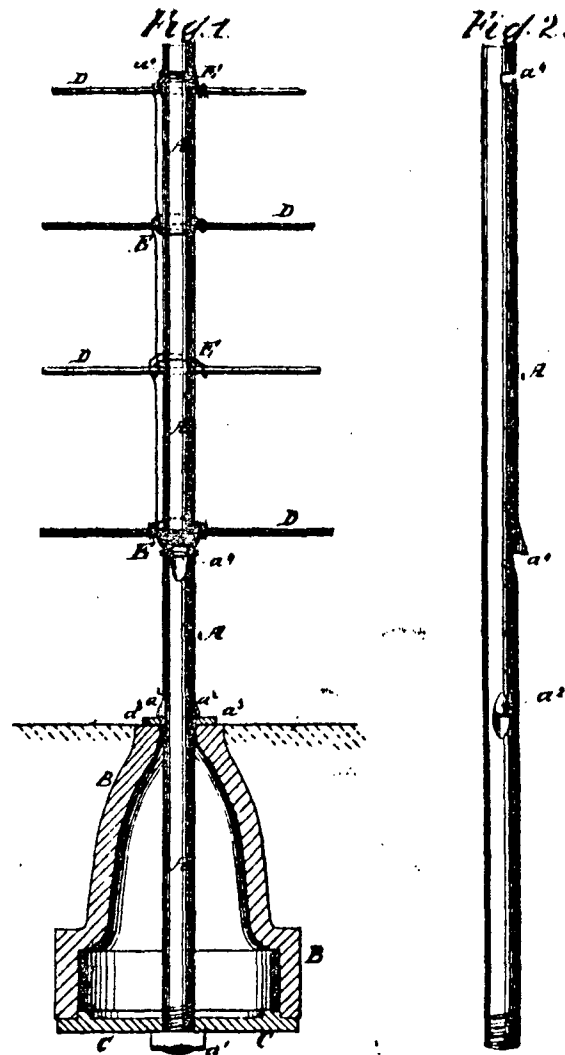

WITNESSES:

E. Wolff
Joseph C. Borroughs

INVENTORS

G. W. Chandler
S. H. Deering
BY *Minutis*

ATTORNEYS.

Figure 63. Illustration of ceramic fence post holder from Mrs. Anderson's collection

CHAPTER SEVEN: SUMMARY AND CONCLUSIONS

Summary

Historical and archaeological data have been examined in an attempt to reconstruct the activities associated with the pottery industry in Moingona. Initially this discussion focused on the ecological and geological setting in which the potteries were located. The environmental factors necessary for the establishment of the pottery industry were all present in Boone County, namely coal, clay, timber, and water. Coal and clay were acquired from the Coal Measures; the timber and water were obtained from the Des Moines River Valley and the Des Moines River.

Secondly a brief history of the settlement of Moingona and the role of the railroad in its development were discussed in relation to pottery manufacturing.

Thirdly through the use of historical data the operation of the Moingona potteries was discussed as well as the process of pottery manufacture.

Finally the archaeological investigation of the Moingona Pottery Works (13BN120) and the Flint Stone Pottery (13BN132) was presented. The main purpose of the latter was to discuss the functional vessel types of the Moingona ware, set up categories of kiln furniture used in stacking the kiln, and provide examples of cobalt blue designs. This information was

provided for comparison of data from other 19th century Iowa potteries. The attempt to correlate the archaeological remains with the historical data provided by the order forms from the two potteries was not entirely successful -- the main reason being the lack of reconstructable vessels from which the capacity in gallons could be determined. If these correlations could be made, it would be a valuable aid for estimating capacities when only the diameter or height of a vessel was known. Also it is not entirely clear what distinctions were made between vessel categories listed on the order forms from the two potteries. Was size alone the main distinction between a fruit jar and a preserve jar, or between a bean pot and a butter pot? Until more reconstructable vessels are recovered these questions will probably remain unanswered.

Conclusions Regarding the Stoneware Industry at Moingona

In general the linkage between the archaeological and archival data was good. The linkage provided direct information that site 13BN120 was the location of the Moingona Pottery Works and that site 13BN132 was the location of the Flint Stone Pottery. Pottery was found with the names of the potteries stenciled on them and archival data, such as order forms, were found for both potteries. Historical records, specifically order forms and accounting books, provided the basis for the discussion of ware according to functional vessel types and to

reconstruct the ceramic technology involved at the two potteries. The archaeological record from the Moingona potteries suggest jiggers and jollies were used in the production of much of the ware, such as milk pans and lids, because of their uniformity in size and absence of finger impressions, indicating hand throwing.

In addition to the information on the development of the pottery industry many of the socio-cultural activities were reconstructed. This can be seen from the variety of economic activities engaged in by individuals associated with the Moingona potteries. These occupations included: dry goods and grocer, butcher, coal mine inspector, coal agent, operator of a confectionary store, and various selling positions.

Other information discovered in this study was the extent of the communication network among potteries in Iowa and surrounding states. The existence of this network was discovered in the letters of G. W. Chandler and many of the potters and potteries listed may not have previously been known. Further study could be done to determine what is known about these potters and potteries listed in Chandler's letters.

Concluding Perspective on Reasons for Decline of Pottery Industry

In general the wealth of historical data provided valuable information about the Moingona potteries, however,

there are still gaps in the account, such as reasons for the potteries declining. There were probably a variety of factors responsible for the decline of the potteries. One of the possible factors involved in the decline of the potteries may have been the increase in the price of coal, wood, and labor, which made it unprofitable to manufacture pottery. Moingona businesses were very dependent on the coal mines, the main industry, and their fortunes rose and fell with the amount of coal mined. Several events at the coal mines greatly affected Moingona. There were repeated strikes by miners reported in the Boone County Democrat during the years 1870, 1874, 1876, 1878, and 1881. In two cases these strikes resulted in the bankruptcy of mining companies (Boone County Democrat: October 7, 1885). An 1880 report in the Boone County Democrat (April 28, 1880) indicates that

Moingona has lost considerable of its population on account of the small amount of mining that is done there now.

The mines also began to be worked out in Moingona, causing many of the miners to move. This increased the price of coal in Moingona because it would have to be brought in from longer distances.

Technological advances were another factor for the decline of the stoneware industry by making it possible to produce inexpensive vessels made from tin and glass. Harold F. Guiland (1971:68) comments on one such replacement of stoneware

The lard pot, or "common pot" . . . was finally replaced for that function in the 1870's by a mass produced tin pail with a close-fitting lid and bale.

An even greater blow to the stoneware industry was the increasing use of glass containers of all types. Guillard (1971:70-71) discusses the use of glass containers

By 1850 the glass industry was rapidly expanding and was able to produce bottles and jugs much more cheaply than stoneware potters could After the Civil War commercial food packers were also using great quantities of glassware, rather than stoneware, because the customer could see what he was buying.

The importance of the customer seeing what was in a container guaranteed the popularity of the "Mason jar" over stoneware preserve and fruit jars.

The screw-top glass "Mason jar" was patented in 1858 and glass factories soon dominated the market Food preserved in the glass jars could be checked for spoilage and at the first signs could be saved by immediate use (Guillard 1971:69-70).

Another technological development that meant a decline in stoneware products was the kerosene lamp

Kerosene lamps were invented about 1859 and by 1865 were the most common means of producing artificial light. As candles and fat lamps fell into disuse, country potters had fewer calls for household lighting fixtures (Guillard 1971:71).

Improved refrigeration also decreased the demand for stoneware containers. Because of their large size, the containers were impractical for the small iceboxes.

Industrialization probably played a part in the decline of the potteries in Moingona. The newer or better equipped potteries could employ more steam power for such things as steam wheels which would mean greater efficiency in production.

One final explanation for the decline of potteries may have been their own competition. Taking one year as an example, in 1872 there were at least five potteries in operation within ten miles of each other. The potteries were: Kegley & Terry in Boonsboro; M. W. Griffee in Boone; the Coal Valley Pottery of Comfort & Elliott; the Moingona Pottery Works and the Flint Stone Pottery in Moingona. All five were competing for basically the same markets for their ware. Several of the potteries tried to specialize in certain products besides manufacturing the regular line of utilitarian ware. Examples of these specialities are the Flint Stone Pottery with drain tile, and the Coal Valley Pottery with well tubing. It was one way for these potteries to compete with the older and larger potteries such as the Moingona Pottery Works. Drain tiles are the type of product that should not require frequent replacement and once the local market was supplied with tile the cost of shipping them long distances to other markets would become prohibitive (Dobson 1928:255-256). Well tubing would probably involve a similar problem.

Probably no single event caused the Moingona potteries to go out of business, but a combination of factors such as those

previously mentioned may have been too much to overcome. Like the stage coach, clipper ship, flintlock rifle, chamber pot, and quill pen, utilitarian stoneware had simply outlived its usefulness and was replaced by newer products of an increasingly technological orientated society.

Epilogue: A Final Glance at the Past and
a Look to the Future

The history of American technology is as worthy of our attention as any of the military or political events of the past. It is also one of the more neglected aspects of history because it may not be as colorful or exciting, and there is a lack of recorded material about it. We can not afford to neglect such an important part of our heritage by destroying the archaeological sites that may be the primary source of data on early American industries. It is for these reasons that if possible large scale excavations should be undertaken at both the Moingona Pottery Works (13BN120) and the Flint Stone Pottery (13BN132). If these sites are destroyed a valuable source of information of the nineteenth century pottery industry in Iowa will be lost forever.

It is important that the correspondence and records of G.W. Chandler be deposited, either as original documents or copies, in a public archive. Chandler's collection is an

invaluable source of information which needs to be preserved as a unique historical resource.

Beyond these matters of cultural resource management, there are several questions concerning the development of the stoneware industry in Iowa which might be elucidated through additional archival research and archaeological investigation of the two Moingona potteries. For example, questions exist as to the geographic extent of the market system of Iowa potteries and the shifts within this system throughout the midwestern United States between 1850 and 1900. A more detailed analysis of Chandler's correspondence and the shipping book of Chandler and Deering for 1875-1877 (Anderson 1974) might provide valuable insights into the transportation system and economic networks within the midwest during the late nineteenth century. Such data might help clarify the reasons for the apparent success of Iowa potteries into the 1880s and their subsequent decline as larger manufacturers in Minnesota and Illinois came to dominate the market.

Similarly, continued archaeological investigations could be framed in an attempt to test certain hypotheses concerning the nineteenth century stoneware industry. It is thought, for example that itinerant potters moved from kiln to kiln as job openings occurred. Furthermore it is thought that each individual potter had his own identifiable

manner of executing design motifs. If this hypothesis is correct, the same specific designs should be found at different stoneware pottery sites within this region. Additional controlled surface collections or a set of excavations might reveal changes in the frequencies of vessel ware categories. Such changes might provide a useful basis for examining the changes in food preparation and preservation techniques -- for example, the shift from the processing of milk products at each individual farm to the movement of bulk milk to central processing plants in towns.

Changes in terms of the production of utilitarian ceramics are still occurring as one observes the rediscovery of folk arts and crafts taking place today. This new awareness has manifested itself in such ways as an increased interest in antique collecting and a desire to return to a way of life "closer to the soil." One result of this increased interest is the manufacture of reproductions of many of the early household utensils, such as pewter dinnerware, handmade wooden furniture, and stoneware vessels. Perhaps history does repeat itself and the social habits that once were a cause of the decline of the stoneware industry will cause a revival of that industry again.

BIBLIOGRAPHY

Abstract of Title to the following described real estate situated in Boone County, Iowa. Lots two (2) and three (3) in Block seventeen (17) in Blair's Addition to Moingona, Iowa, except coal and mineral, and Lots one (1), two (2), three (3), four (4), five (5), six (6), eight (8) and seven (7) except North twenty (20) feet of said Lot seven (7) in Block eighteen (18) in Blair's Addition to Moingona, (presently owned by Donald M. and Grace J. Wilhite) Boone County Abstract & Loan Company, Josephson Brothers, Boone, Iowa.

Anderson, Eloise

1974 Collected Material of G. W. Chandler. 1234 East 13th Street, Des Moines, Iowa.

Andreas, A. T.

1875 Illustrated Historical Atlas of the State of Iowa. Chicago, Andreas Atlas Company.

Barber, Edwin Atlee

1909 The Pottery and Porcelain of the United States, an Historical Review of American Ceramic Art from the Earliest Times to the Present Day. New York, G. P. Putnam's Sons.

Beckwith, C. E.

1872 Pottery. Observations on the materials and manufacture of terra-cotta, stone-ware, fire-brick, porcelain, earthen-ware, brick, majolica and encaustic tiles. New York, D. Van Nostrand.

Beecher, Milton F.

1915 An Investigation of Iowa Fire Clays. Iowa State College of Agriculture and Mechanic Arts 14, Number 4. Bulletin 40. Engineering Experiment Station, Ames, Iowa.

Beyer, S. W.

1896 Geology of Boone County. Iowa Geological Survey, Vol. V, 177-242. Annual Report for 1895 with Accompanying papers. Des Moines, published for the Iowa Geological Survey.

- Beyer, S. W. and I. A. Williams
 1904a Directory of Iowa clay workers. Iowa Geological Survey 14:621-641. Annual report, 1903, with accompanying papers. Des Moines, published for Iowa Geological Survey.
- 1904b The geology of clays. Iowa Geological Survey 14:377-554. Annual report, 1903, with accompanying papers. Des Moines, published for Iowa Geological Survey.
- 1904c Technology of clays. Iowa Geological Survey 14:29-318. Annual report, 1903, with accompanying papers. Des Moines, published for Iowa Geological Survey.
- Beyer, S. W., G. W. Bissell, I. A. Williams, J. B. Weems, and A. Marston
 1904 Clays and clay industries of Iowa. Iowa Geological Survey 14. Annual report, 1903, with accompanying papers. Des Moines, published for Iowa Geological Survey.
- Billington, Dora M.
 1962 The Technique of Pottery. New York, Hearthsides Press.
- Binns, Charles F.
 1967 The Potter's Craft. New Jersey, D. Van Nostrand Company.
- Boone City Directory
 1897 J. J. Kirby, Publisher. Boone Daily News, Printers. Boone, Iowa.
- Boone County Advocate. July 5, 1866 - March 13, 1873.
- Boone County Democrat. February 26, 1868 - October 26, 1887.
- Boone County Index. March 29, 1866 - August 27, 1867.
- Boone County Republican. August 2, 1876 - August 8, 1877.
- Boone News Republican. September 13, 1965, Vol. LXXVII, No. 213, Vol. LVIV, No. 292. Centennial Edition. Pp. 4-8.
- Boonsboro Democrat. August 19, 1857 - March 22, 1866.
- Brown, Mabel Nair
 1971 Moingona - a Rich Historical Past, in The Ogden Reporter, Wednesday, June 9, 1971.

- Cardew, Michael
1969 Pioneer Pottery. New York, St. Martin's Press.
- Clarke, S. J.
1902 A Biographical Record of Boone County Iowa. New York and Chicago, S. J. Clarke Publishing Company.
- Dobson, Edward
1928 A Rudimentary Treatise on the Manufacture of Bricks and Tiles. London, Crosby Lockwood and Son.
- Forsyth, Gordon M.
1934 Art and Craft of the Potter. London, Chapman & Hall Ltd.
- Galpin, S. L.
1924 The Geology of the More Refractory Clays and Shales of Iowa. Iowa Geological Survey 31. Annual reports, 1923 and 1924, with accompanying papers. Des Moines, published for Iowa Geological Survey.
- Goldthwait, N. E. (editor)
1914 History of Boone County Iowa. 2 Vols. Chicago, Pioneer Publishing Company.
- Gradwohl, David M.
1973 Pursuing Pioneer Potters: The Investigation of 19th Century Kilns in the Central Des Moines River Valley. Iowa State University, Ames, Iowa. Paper presented at the 6th Annual Conference of the Society for Historical Archaeology in St. Paul, Minnesota, January 12, 1973.
- Gradwohl, David M., Osborn Nancy M.
1973 A Roster of Reported Archaeological Sites in Saylorville Reservoir, Iowa. Research Report October 1973, Ames, Iowa, Iowa State University Archaeological Laboratory.
- Guilland, Harold F.
1971 Early American Folk Pottery. New York, Chilton Book Company.
- Gwynne, C. S.
1943 Ceramic Shales and Clays of Iowa. Iowa Geological Survey 38:263-378. Annual reports, 1940 and 1941, with accompanying papers. Published by the State of Iowa.

Hovey and Frame

- 1902 Republican Atlas, Boone County, Iowa. Knoxville, Iowa, Hovey and Frame.

Iowa Official Census

- 1850 Original in Census Records Department, Iowa State Historical Society, Des Moines, Iowa.
- 1856 Original in Census Records Department, Iowa State Historical Society, Des Moines, Iowa.
- 1860 Original in Census Records Department, Iowa State Historical Society, Des Moines, Iowa.
- 1870 Original in Census Records Department, Iowa State Historical Society, Des Moines, Iowa.
- 1880 Original in Census Records Department, Iowa State Historical Society, Des Moines, Iowa.
- 1885 Original in Census Records Department, Iowa State Historical Society, Des Moines, Iowa.
- 1895 Original in Census Records Department, Iowa State Historical Society, Des Moines, Iowa.

Kennedy, Olive

- 1974 Minutes of the Moingona (Iowa) Town Council Meetings.

Land Deed Record, Boone County, Iowa

- 1869 Dated June 8. Book E, p. 206. Boone County Auditors Office.
- 1870 Dated February 28, Book 5, p. 187.
- 1892 Dated December 6. Book G.

Leach, Bernard

- 1940 A Potter's Book. London, Faber and Faber Limited.

Lokken, Roscoe L.

- 1942 Iowa Public Land Disposal. Iowa City, The State Historical Society of Iowa.

Mc Farland, Julian E.

- 1969 A History of the Pioneer Era on the Iowa Prairies. Lake Mills, Iowa, Graphic Publishing Company.

- Miller, Mary
1974 Conversations on clay and glazes-from Boone County.
216 Cedar Street, Boone, Iowa.
- Montana Standard September 12, 1868 - September 3, 1870.
- New City Directory of Boone, Iowa, 1885-1886
1885 Boone County Republican Steam Printing Office.
- Noel Hume, Ivor
1969 Historical Archaeology. New York, Alfred A. Knopf.
- Parker, Nathan H.
1857 Iowa as it is in 1857. Chicago, Keen and Lee.
- Parmelee, Cullen W.
1951 Ceramic Glazes, 2nd edition. Chicago, Industrial
Publications Inc.
- Peterson, William J.
1941 Iowa-The Rivers of Her Valleys. Iowa City, The State
Historical Society of Iowa.
- Ramsay, John
1939 American Potters and Pottery. Boston, Hale, Cushman
and Flint.
- Reynolds, John D.
1970 Coalport and its Relationship to the Early Historic
Pottery Industry in the Des Moines River Valley.
Masters Thesis in Anthropology, Iowa State
University, Ames, Iowa.
- Rhodes, Daniel
1957 Clay and Glazes for the Potter. Philadelphia,
Chilton Book Company.
- Roy, Vincent A.
1959 Ceramics-An Illustrated Guide to Creating and
Enjoying Pottery. New York, McGraw-Hill.
- Schlick, W. J.
1915 An Investigation of Test of Iowa Shale Drain Tile,
Official publication of Iowa State College of
Agriculture and Mechanic Arts 16, Number 43,
Bulletin 49. Engineering Experiment Station, Ames,
Iowa.

- Schulte, Barbara
 1974 The Nineteenth Century ceramic industry at Coal Valley: Archaeology of 13BN111 (Noah Creek Kiln). Ames, Iowa: Iowa State University. Unpublished Masters Thesis.
- Searle, Alfred B.
 1915 Clays and Clay Products. London, Sir Isaac Pitman & Sons.
- Searle, Alfred B.
 1929 The Encyclopedia of the Ceramic Industries, Vols. 1 (A-E); 2 (F-P); 3 (Q-Z). London, E. Benn., Limited.
- Searle, Alfred B.
 1953 The Clayworker's Hand-Book; A Manual for all Engaged in the Manufacture of Articles From Clay, 5th edition. London, Charles Griffin & Company Limited.
- Shepard, Anna O.
 1956 Ceramics for the Archaeologist. Publication 609. Washington, D.C., Carnegie Institution of Washington.
- Smith, Klarize Mae
 1942 The economic and social development of Iowa from 1860 to 1870. Unpublished Master's thesis. Iowa State University, Ames, Iowa.
- Spargo, John
 1938 Early American Pottery and China. New York, D. Appleton-Century Company.
- The Boone County Messenger
 1938 History of Boone County Township in The Boone County Messenger, Thursday, August 18, 1938.
- The Ogden Reporter. June 6, 1874.
- The Ogden Reporter. June 27, 1874.
- Town Lot Deed Record
 1871a Dated January 30. Book D, page 481. Boone Co. Auditors Office.
 1871b Dated January 30. Book 5, p. 347.
 1871c Dated September 21. Book F, p. 591.
 1874 Dated February 19. Book 7, p. 271.

Town Lot Deed Record

1879 Dated August 12. Book 11, p. 587.

1895 Dated April 29. Book T.D. 3, p. 101.

Union Historical Company

1880 The History of Boone County, Iowa. Des Moines, Union Historical Company.

United States Army Corps of Engineers

1964 Saylorville dam and reservoir, Des Moines River, Iowa. Rock Island, Illinois: United States Army Corps of Engineers, North Central Division, Rock Island District (Map and brochure).

Van Schoick, Emily C. (ed.)

1963 Ceramic Glossary. Columbus, Ohio, the American Ceramic Society.

Watkins, Laura Woodside

1950 Early New England Potters and Their Wares. Cambridge, Mass.

Webster, Donald Blake

1971 Early Canadian Pottery. Greenwich, Connecticut, New York Graphic Society Limited.

White, Charles A.

1870 Report on the Geological Survey of the State of Iowa, to the Thirteenth General Assembly, January 1870, containing results of examinations and observations made within the years 1866, 1867, 1868, and 1869, Vol. 2. Des Moines, printed and published by Mills and Co.

Wilder, David R.

1974 Conversations on ceramic material from the Moingona Pottery Works (13BN120) and the Flintstone Pottery (13BN132).

ACKNOWLEDGMENTS

My appreciation is extended to the following people who helped make this study possible.

Dr. David M. Gradwohl, my major professor and head of my committee, who provided valuable assistance and overall direction for the study.

Committee members, Dr. Michael Whiteford, and Dr. Donald Biggs, and Anthropology staff members, Drs. D. Michael Warren, Patrick Morris, Nancy Tucker-Morris and Mr. William Ringle for providing valuable ideas and suggestions on reworking certain chapters.

Mrs. Mary Miller (Boone, Iowa) who brought the two sites to the attention of Dr. Gradwohl and, along with Dr. David R. Wilder, Head of the Department of Ceramic Engineering, provided expert opinions about glazes and pottery.

Robert Timberlake, Michael Portwood, Donald Heck, and Barbara Schulte, anthropology students, who aided in the archival research and archaeological analysis.

Mrs. Mabel Brown (Ogden, Iowa), Mr. and Mrs. Donald Wilhite (Moingona, Iowa), Mrs. Olive Kennedy (Moingona, Iowa), Mr. Edward Myers (Boone, Iowa), who provided valuable historical material used in the study.

Doratheia Fitzgerald, Librarian at the Ericson Public Library, Boone, Iowa, who provided valuable assistance with

library material.

Mary Baldus (Spencer, Iowa) for the line drawings of the cobalt blue designs, and to Mark Mills for several of his line drawings.

Dr. James P. Reilly, Assistant Professor of Civil Engineering, for his expert help in mapping the area of site 13BN120.

Mrs. Marcia Thompson (Ames, Iowa), who aided in proof-reading.

Mrs. Eloise Anderson (Des Moines, Iowa), who provided some of the most important archival data with the material from the collection of G. W. Chandler.

In conclusion, I owe an enormous amount of thanks to Susan, my wife, for all the assistance and encouragement she gave me while working on this report.

PLATES 1-5

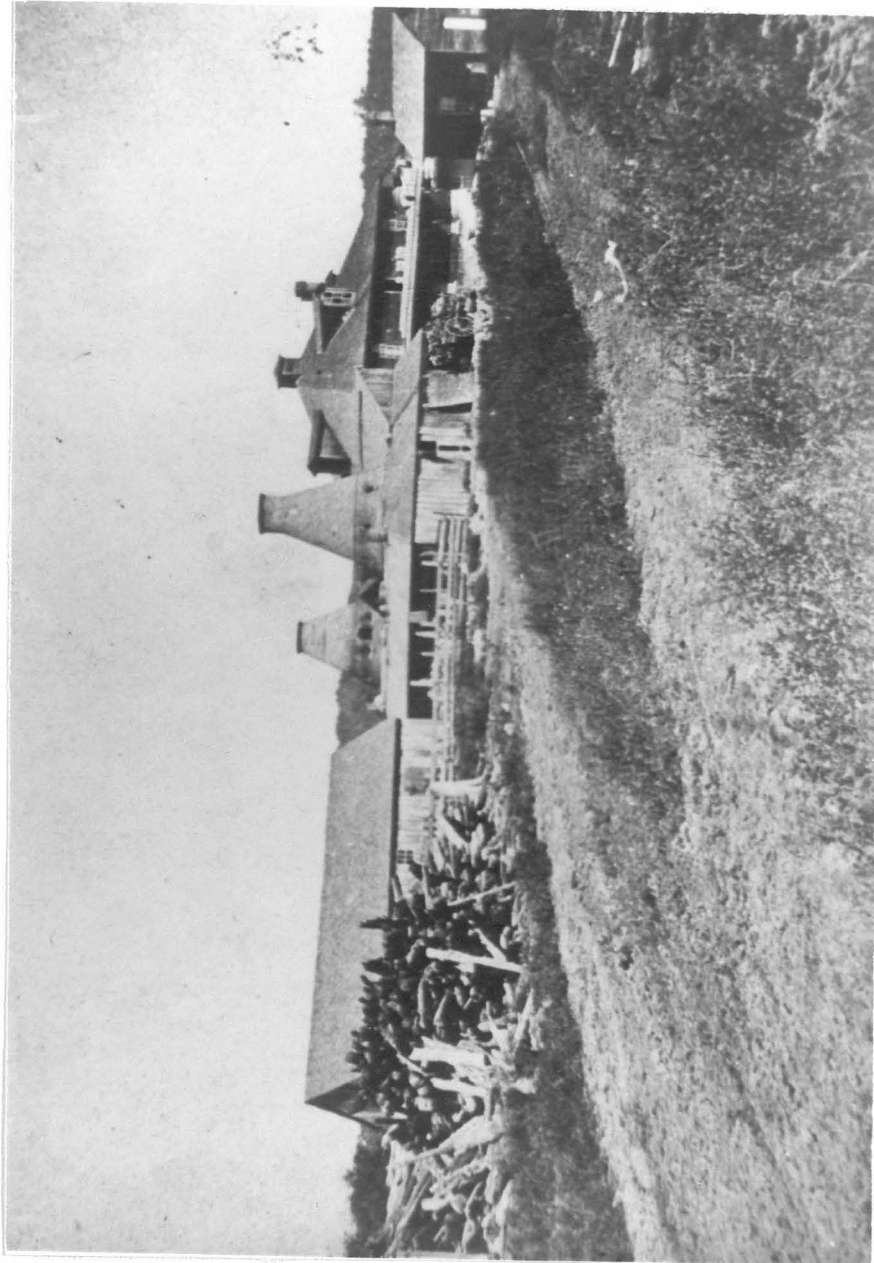

Plate 1. Moingona Pottery showing location of the main building, the two kilns, and the storage sheds



Plate 2. G. W. Chandler's pottery vessels: A) pitcher; B) angel food cake pan; C) butter dish



Plate 3. G. W. Chandler's flower pots: A) small flower pot with raised flower designs; B) large flower pot with scalloped lip and saucer; C) large flower pot with scalloped lip and base with pedestal

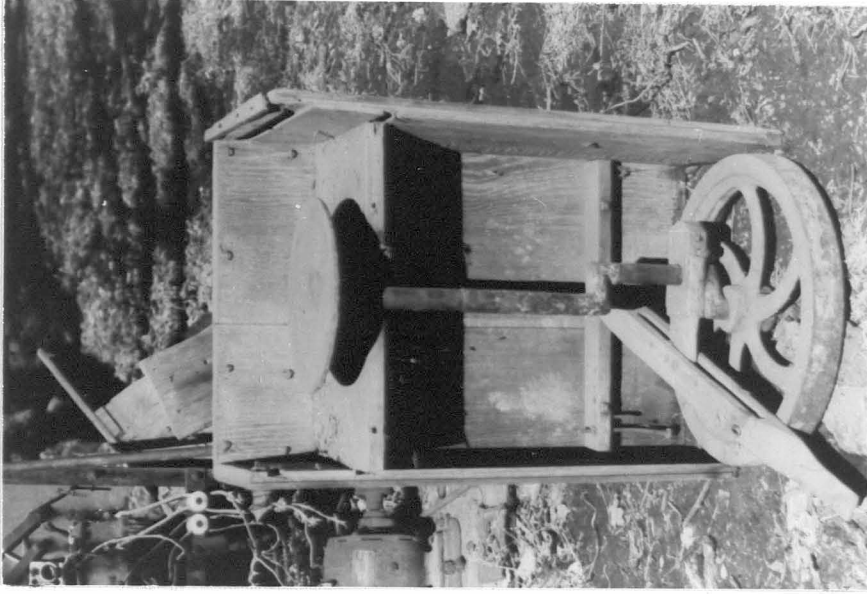

Plate 5. G.W. Chandler's potter's wheel with front part of wooden frame removed, showing back of wooden base, throwing wheel, iron shaft, wooden treadle, and kick wheel

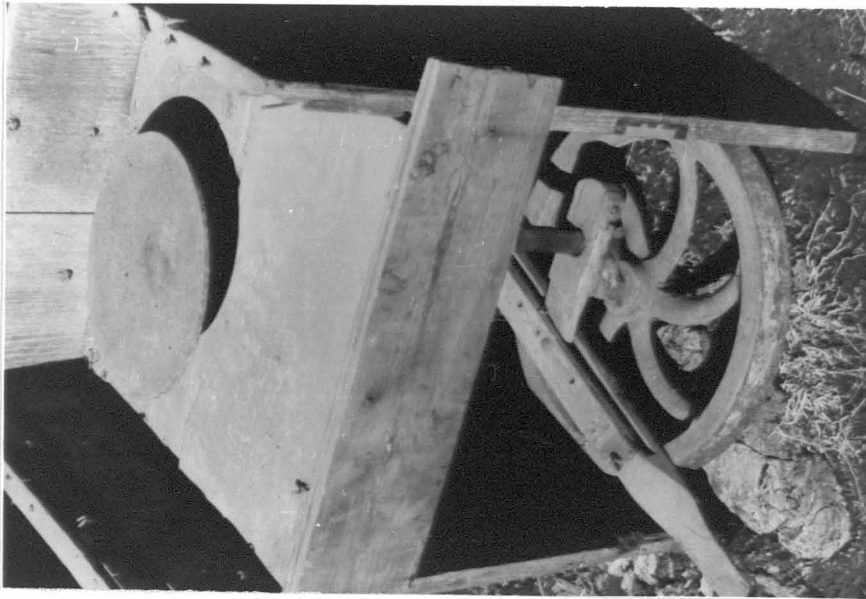

Plate 4. G.W. Chandler's potter's wheel showing wooden frame, throwing wheel, wooden treadle, and kick wheel